



# Airborne Wind Energy

R&D status & outstanding challenges

Roland Schmehl, TU Delft

# Presenter

- Associate Professor at Delft University of Technology
- Co-founder of Kitepower BV
- Coordinator of 2 H2020 projects (AWESCO & REACH)
- AWE-responsible PI in Dutch NWO project NEON
- Co-organizer of AWEC 2015, 2017 and 2019
- Co-editor and editor of 2 Springer textbooks on AWE

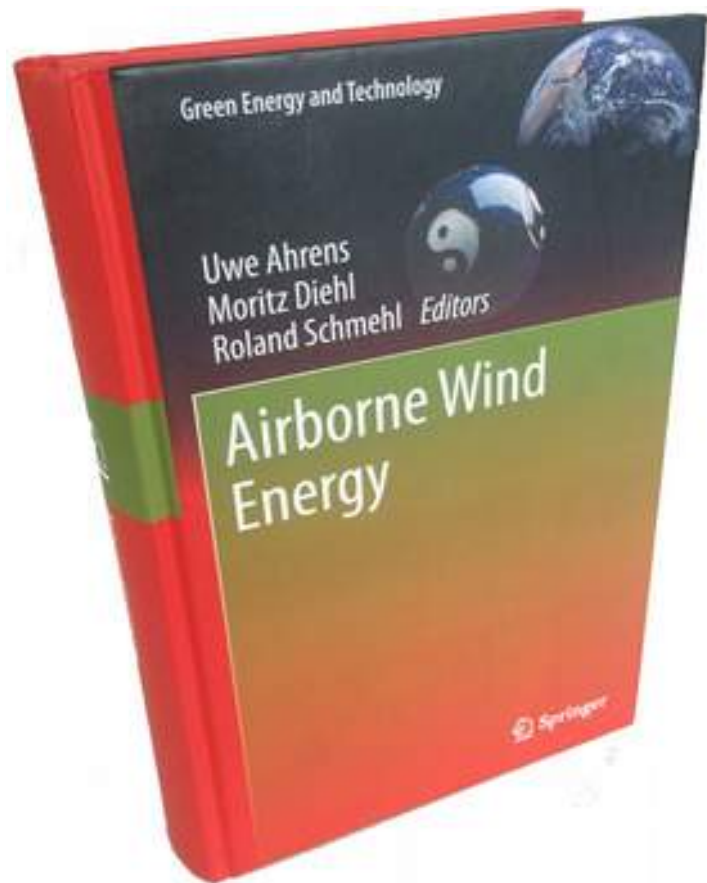

2013

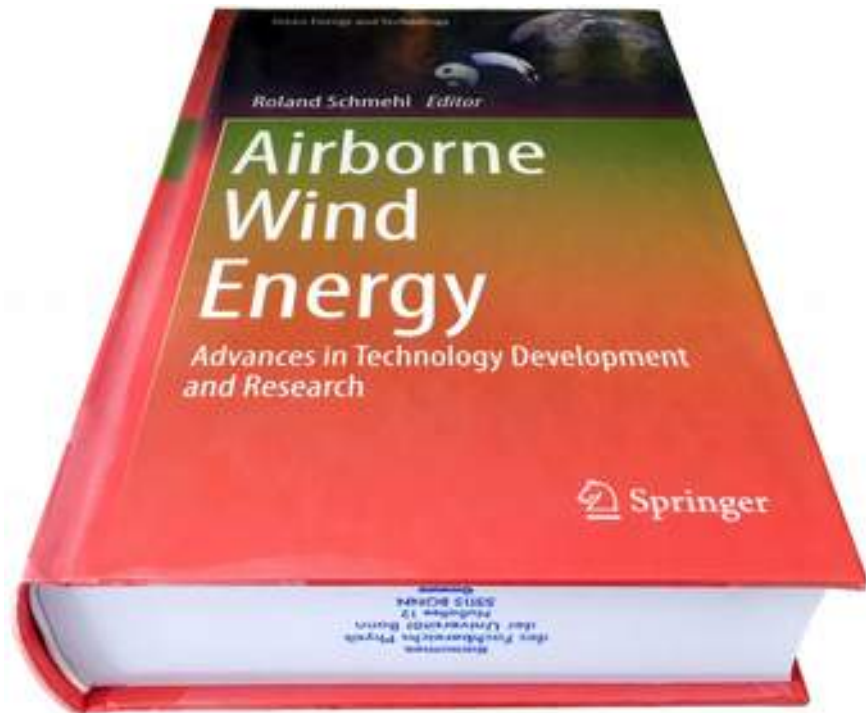

2018

# 4

# Outline

- Fundamental working principles
- Classification of concepts
- Implemented technology demonstrators
- Development challenges
- Research challenges
- Development of the sector

# Fundamental concepts

Miles L. Loyd (1980)

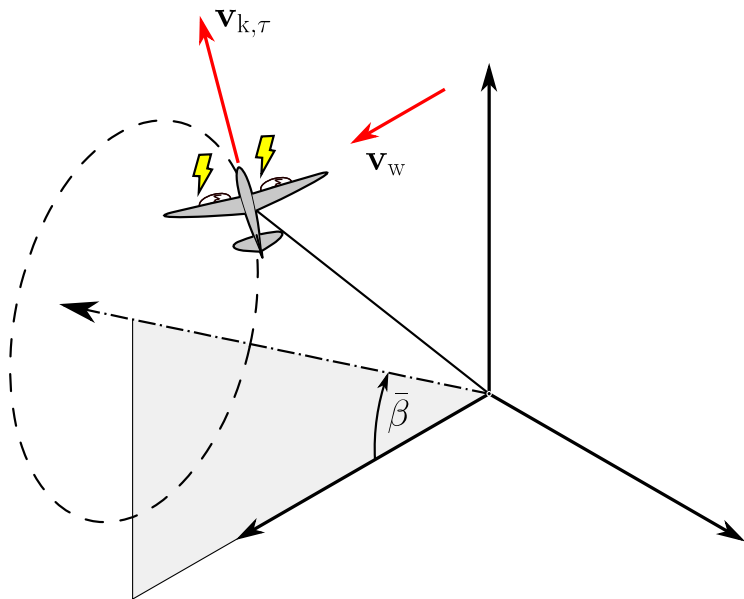

## Drag power:

- Flying wing  $\rightsquigarrow$  shaft power
- Shaft power  $\rightsquigarrow$  electricity ( $\omega \uparrow$ )
- Electricity  $\rightsquigarrow$  conductive tether

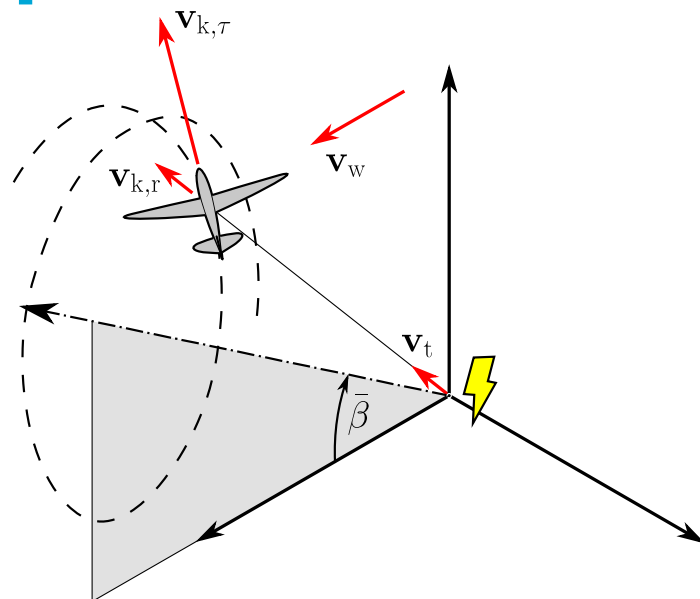

## Lift power:

- Flying wing  $\rightsquigarrow$  traction force
- Traction force  $\rightsquigarrow$  shaft power ( $\omega \downarrow$ )
- Shaft power  $\rightsquigarrow$  electricity

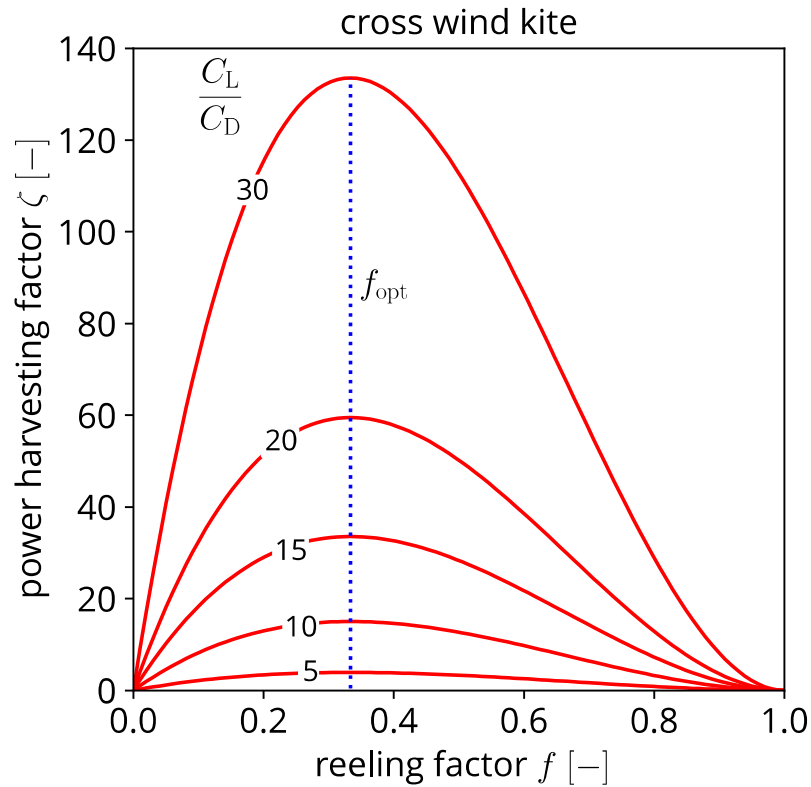
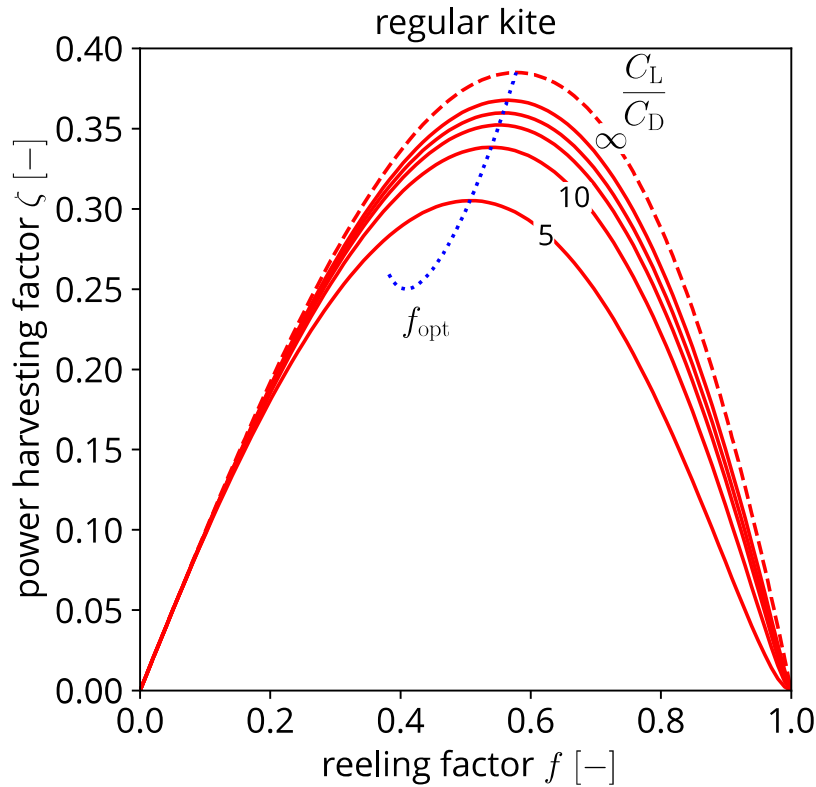

power harvesting factor  $\zeta = \frac{P}{P_w S}$ , wind power density  $P_w = \frac{1}{2} \rho v_w^2$ , reeling factor  $f = \frac{v_t}{v_w}$ ,  
 mechanical power  $P$ , wing surface area  $S$

# Key aspects



- Consumes significantly less material
- Highly adjustable to wind resource
- Access to high altitude wind
- Increased mobility

Image source: Skysails

- More complex than turbines
- Requires reliable & robust control
- Depends on high-performance materials
- Need to revise current regulatory framework

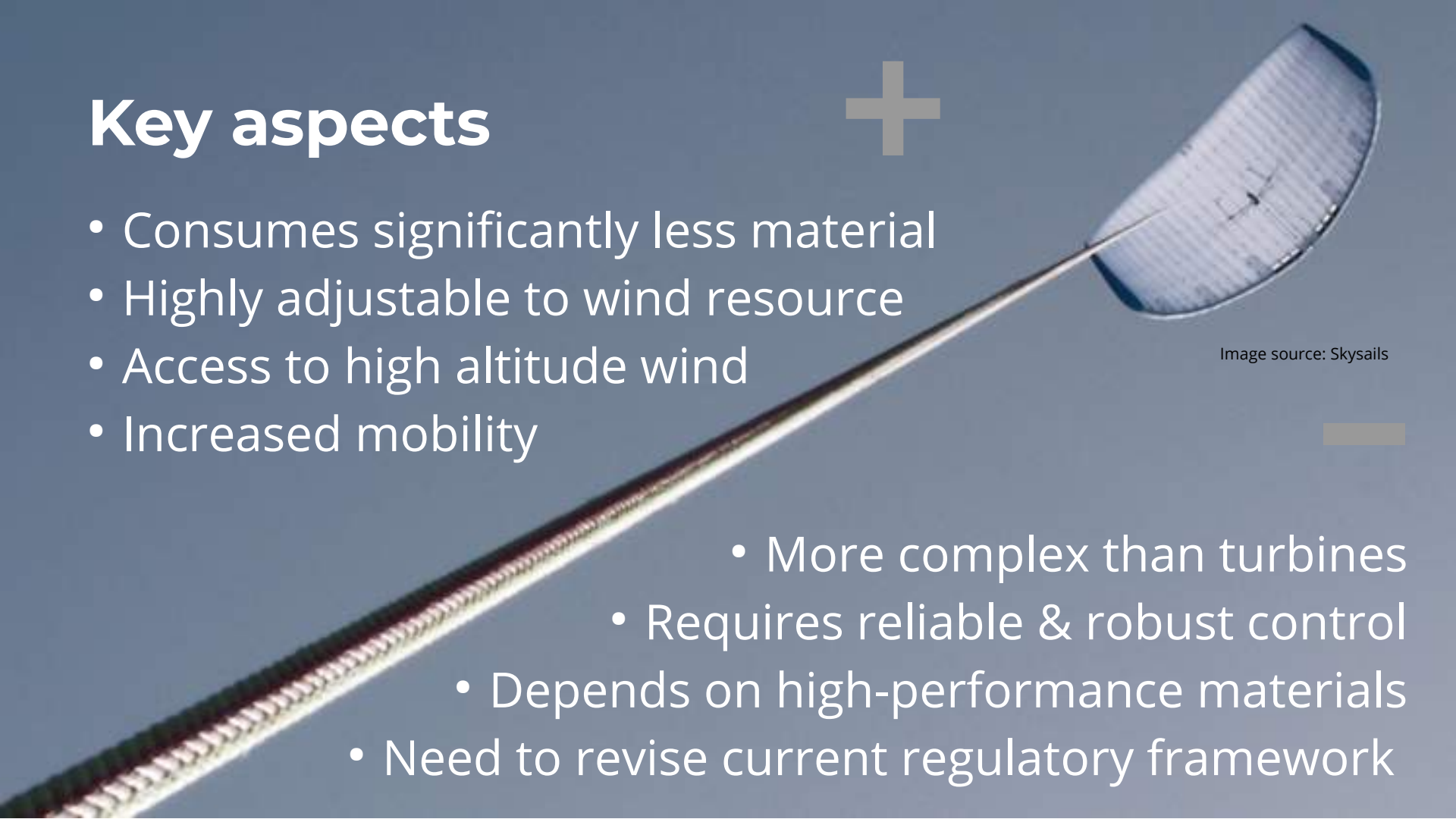

# Technology demonstrators

Kitepower



Enerkite



Ampyx Power



Kitemill



Twingtec



Skysails



KPS



Skypull



Windswept



eWindSolutions





# AWES classification

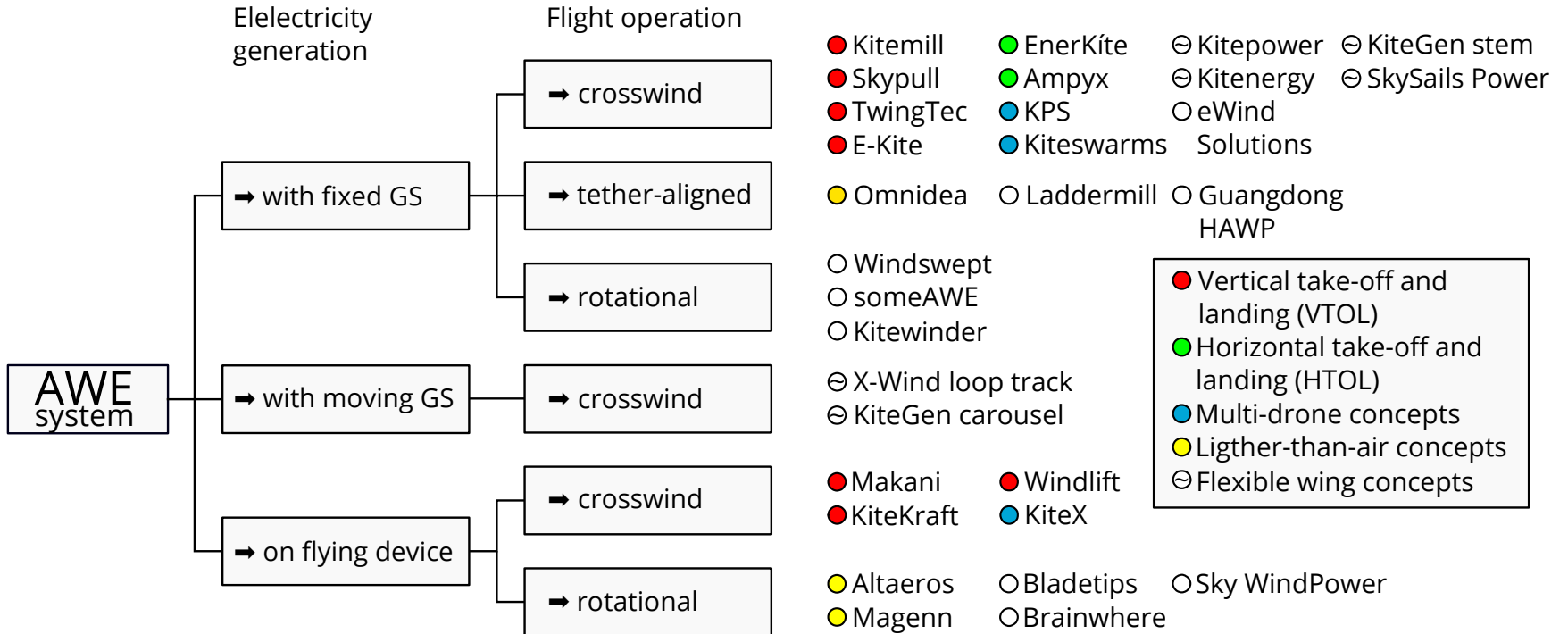

# AWES classification

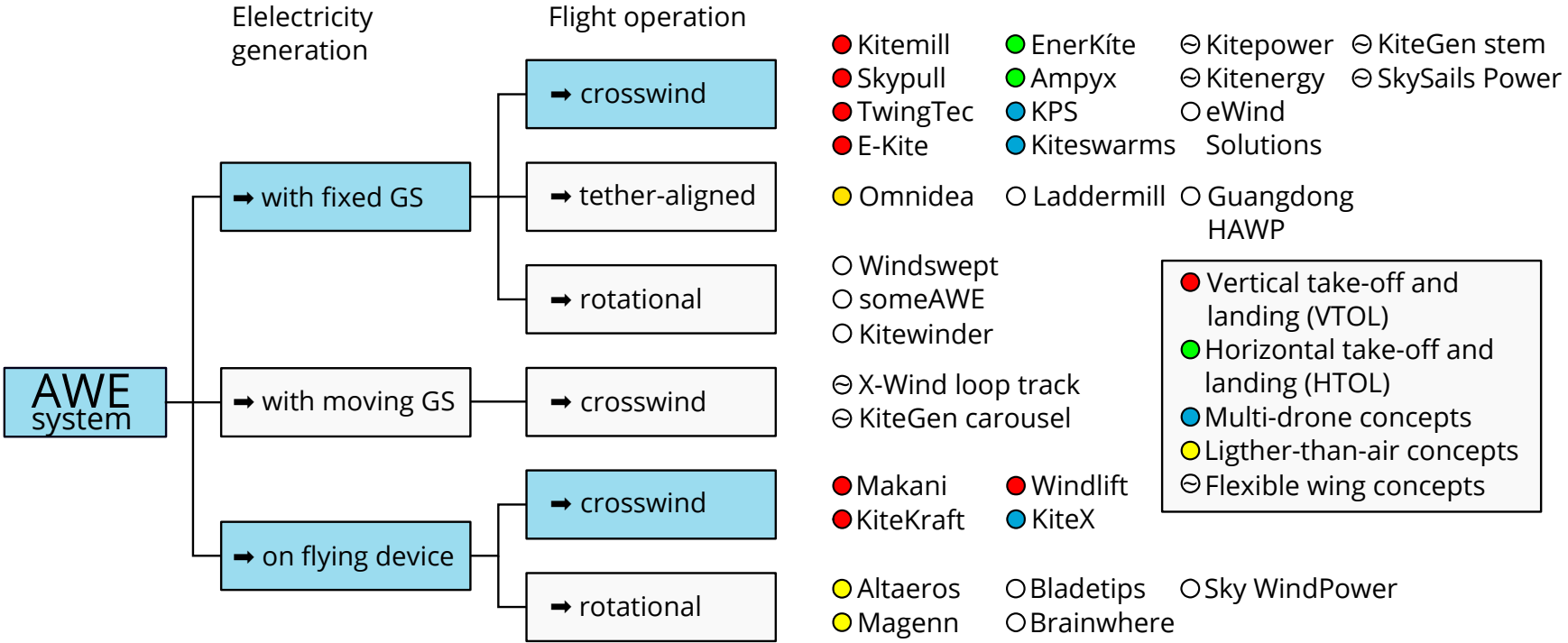

Adapted from: Watson et al. "Future emerging technologies in the wind power sector: a European perspective", Renewable and Sustainable Energy Reviews, 2019.

# Further reading: [awesco.eu/awe-explained](http://awesco.eu/awe-explained)



[Home](#) [News](#) [Projects](#) [People](#) [Results](#) [About](#) [Wiki\(Login\)](#)  [in](#)



## Airborne Wind Energy

An introduction to an emerging technology.

Roland Schmidt

20 Jun 2019



Airborne wind energy (AWE) is the conversion of wind energy into electricity using tethered flying devices. Some concepts combine onboard wind turbines with a conducting tether, while others convert the pulling power of the flying devices on the ground. Replacing the tower of conventional wind turbines by a lightweight tether substantially reduces the material consumption and allows for continuous adjustment of the harvesting altitude to the available wind resource. The decrease in installation cost and increase in capacity factor can potentially lead to a substantial reduction of the cost of wind energy. Wind at higher altitudes is also considered to be an energy resource that has not been exploited so far.

### Table of Contents

- [Historical perspective](#)
- [Development as an industry](#)
- [Presently pursued concepts](#)
- [Conclusion](#)

# Technology demonstrators

- Makani
- Ampyx (→ presentation Jaap Bosch)
- Enerkite
- Twingtec
- Kitemill (→ presentation Lode Carnel)
- Kitepower

# Wing7 (30 kW)



# M600 (600 kW)



California 2017



The logo for MAKANI Hawaii 2018 features a stylized blue icon on the left, resembling a wave or a traditional Hawaiian symbol, followed by the word "MAKANI" in a bold, blue, sans-serif font. Below "MAKANI" is the text "Hawaii 2018" in a smaller, white, sans-serif font.

**MAKANI**  
Hawaii 2018























Karmøy, Norway  
August 2019



# AP-2 (50 kW)



Noordoostpolder 2013



# AP-3 (250 kW)



Marin 2018

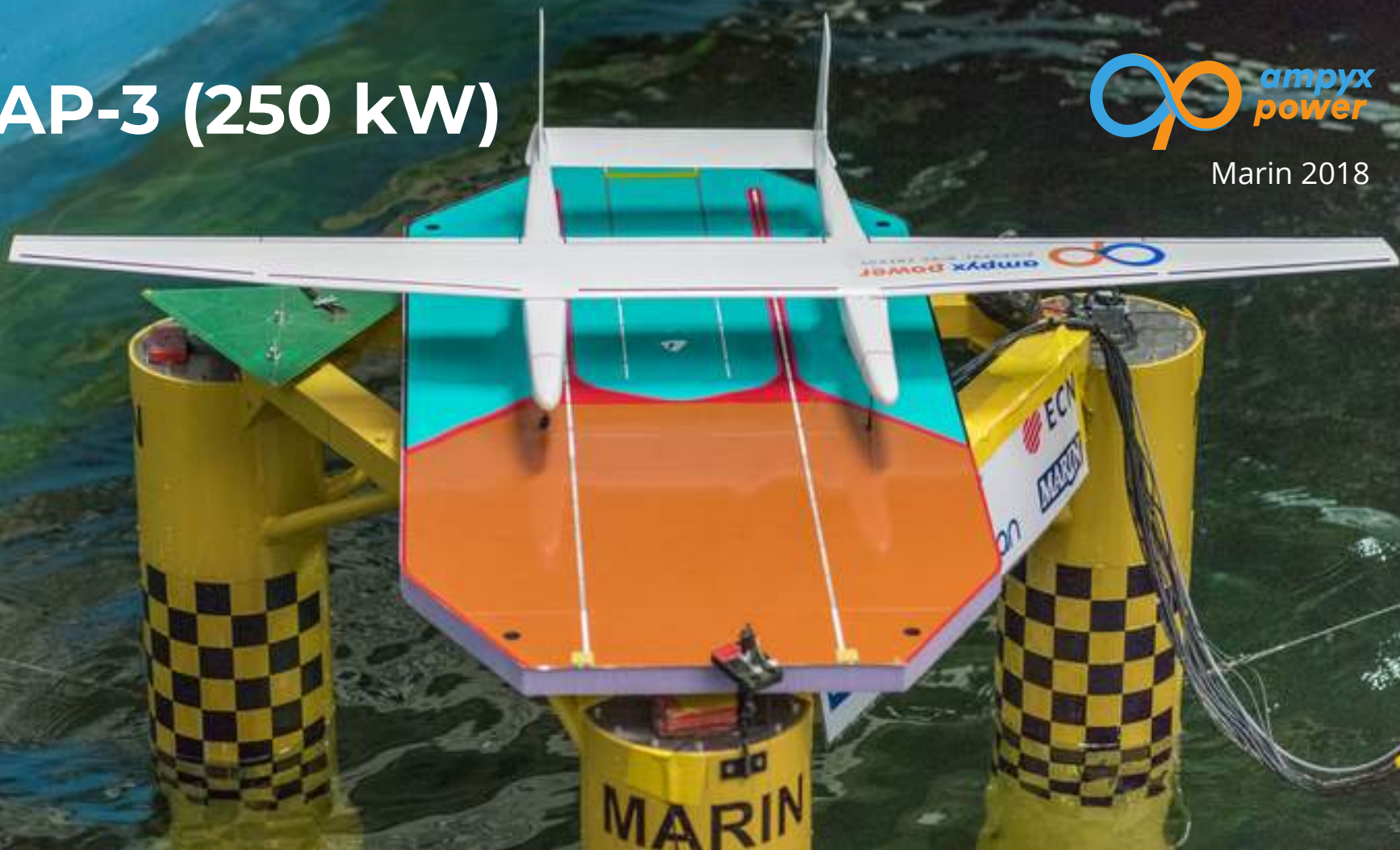







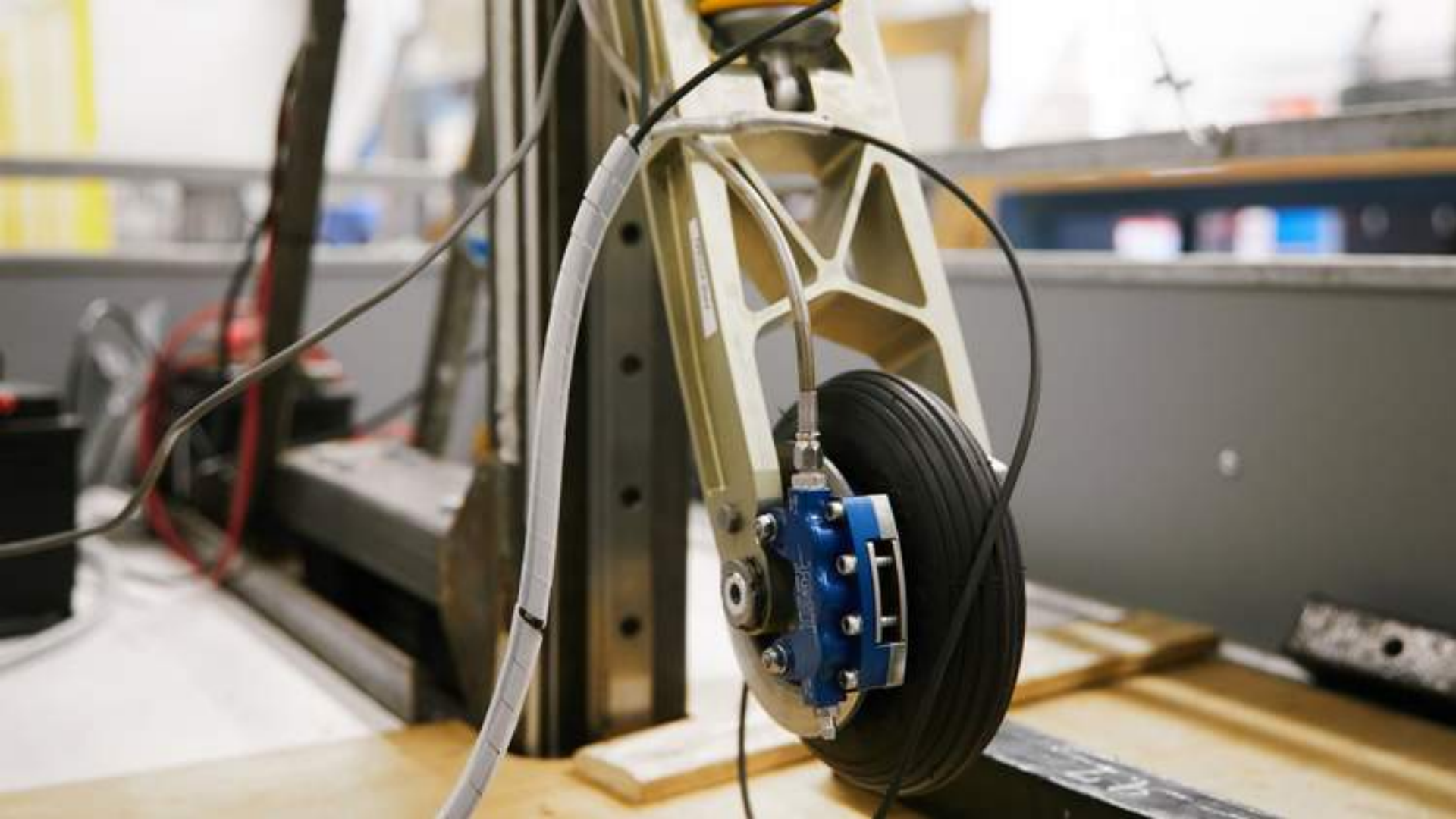





**50kW**



Prototype AP2  
30 households

**250 kW**



Demo AP3 full functionality, certifiable,  
restricted type certification 150 households

**2 MW**



Commercial product AP4 certified,  
minimal cost of energy 1000 households



# Ampyx Power AP4: 2 MW

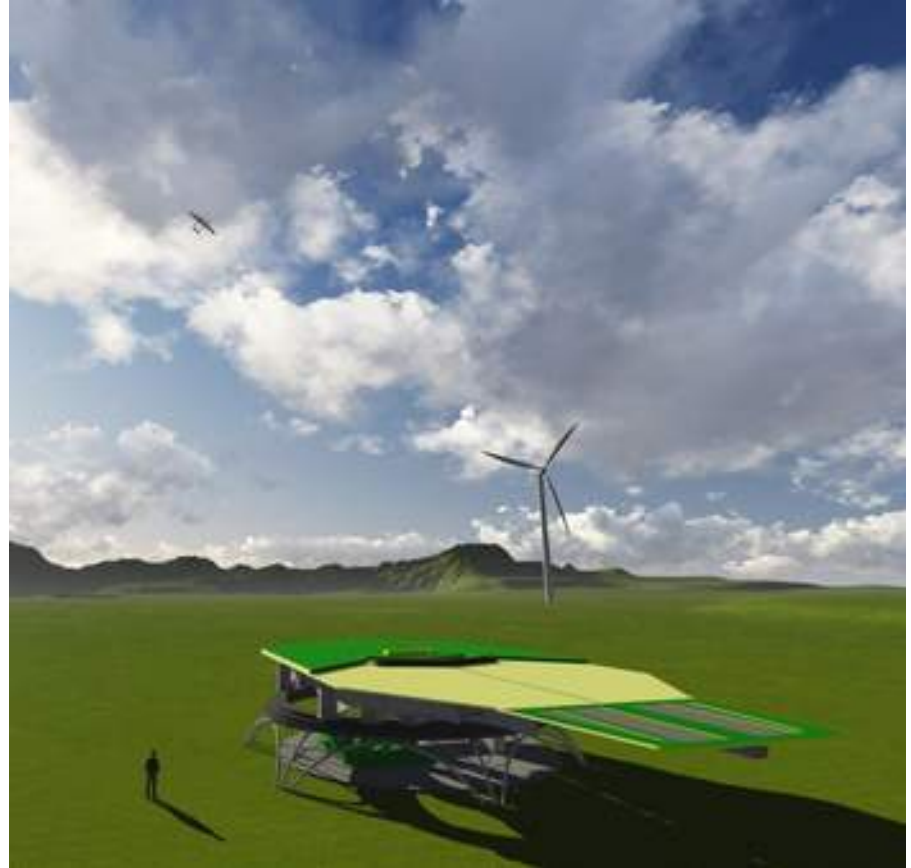

**EnerKite**

Germany 2012



A large white kite with a red tip and the 'EnerKite' logo is flying in a blue sky. Below it, two wind turbines are visible against a dark treeline. The kite is connected to the turbines by thin lines.

# EnerKite

Germany 2014



# EnerKite

Germany 2019









2012







WIND ENERGY 2.0

2019





TwingTec pilot next to turbine with same power







# 25 kW kite power system

 **TU Delft**

2012



# System components

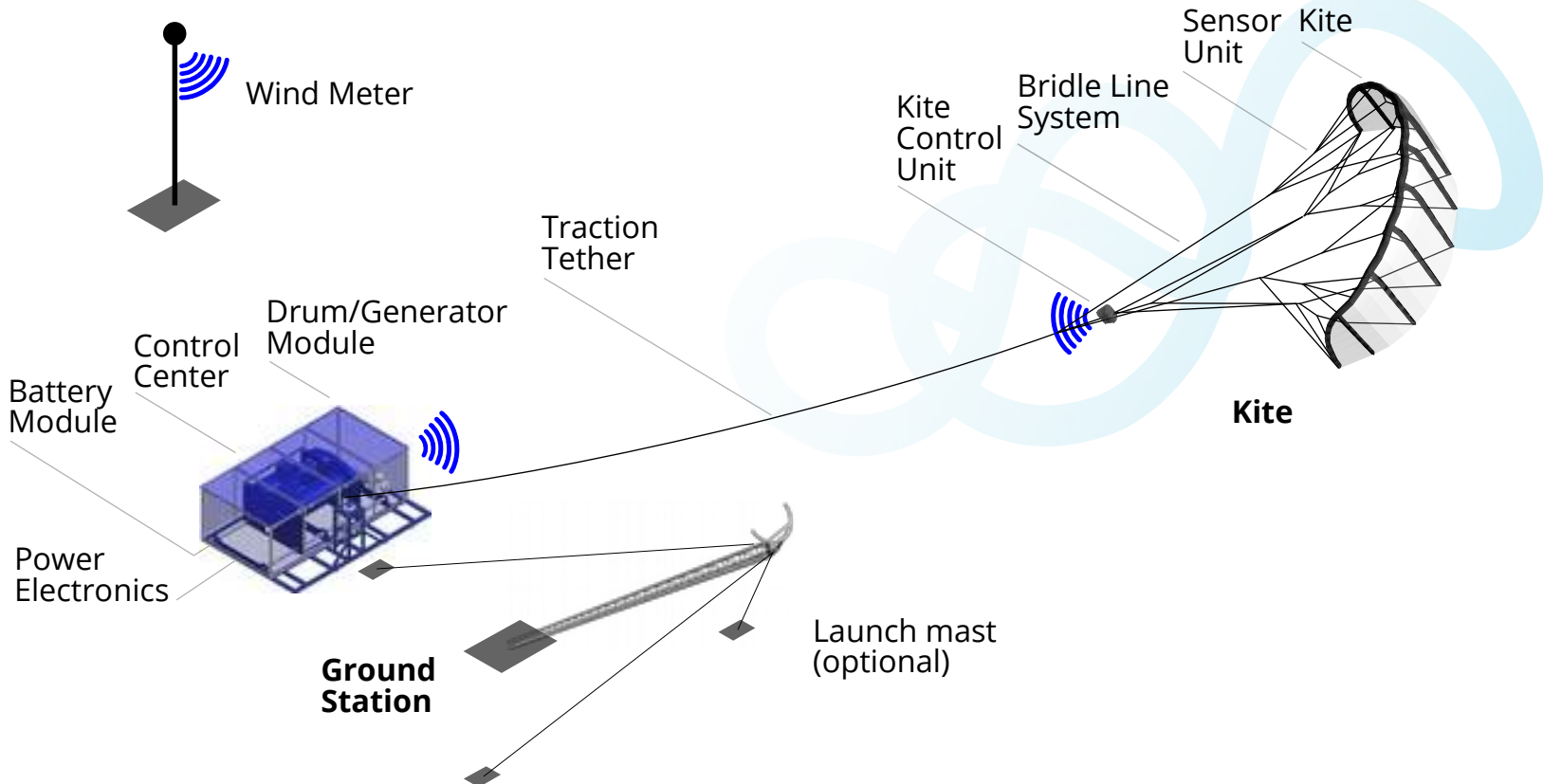

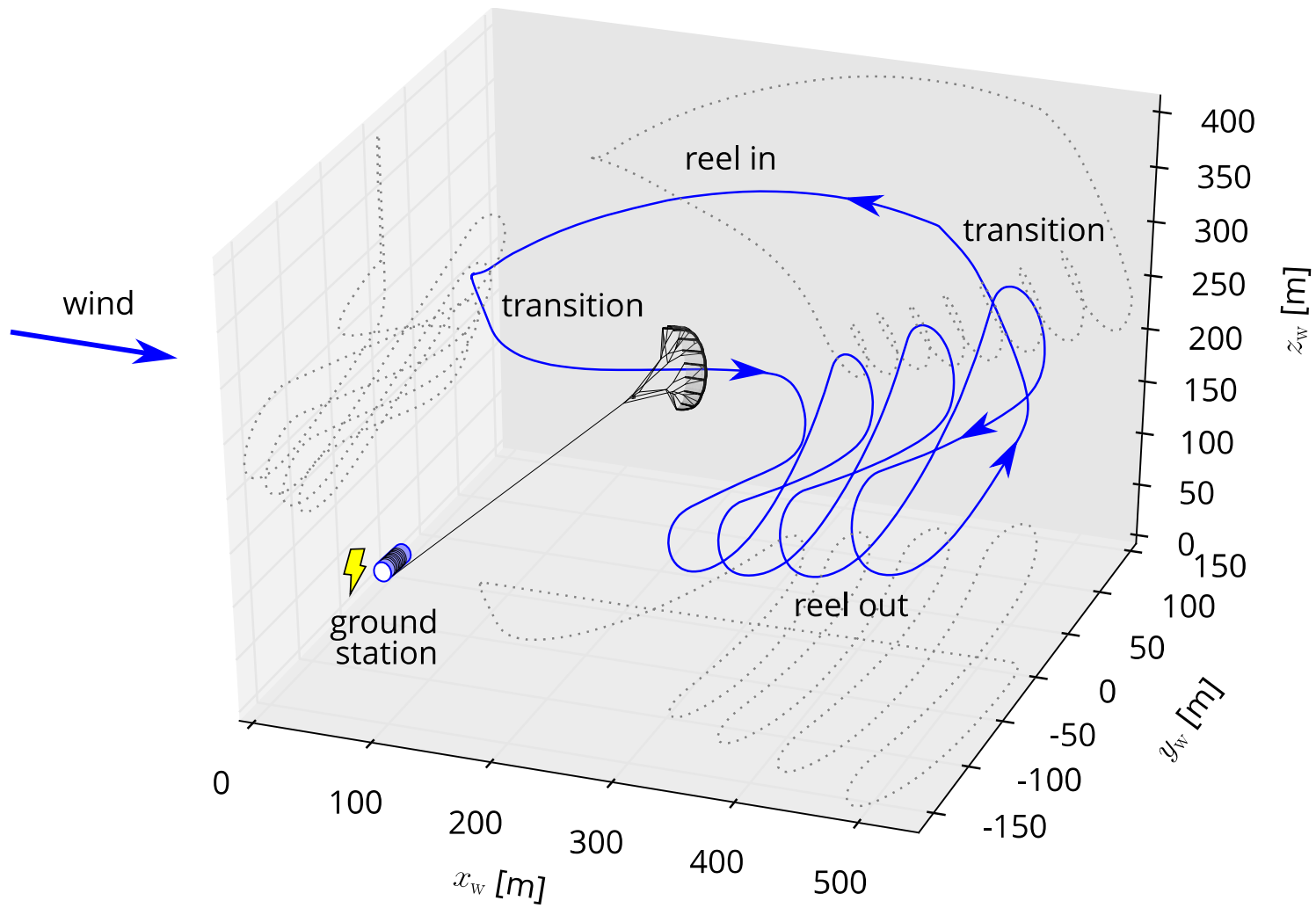



TU Delft V3 25 m<sup>2</sup>



Genetrix Hydra 14 m<sup>2</sup>



TU Delft V3 25 m<sup>2</sup>



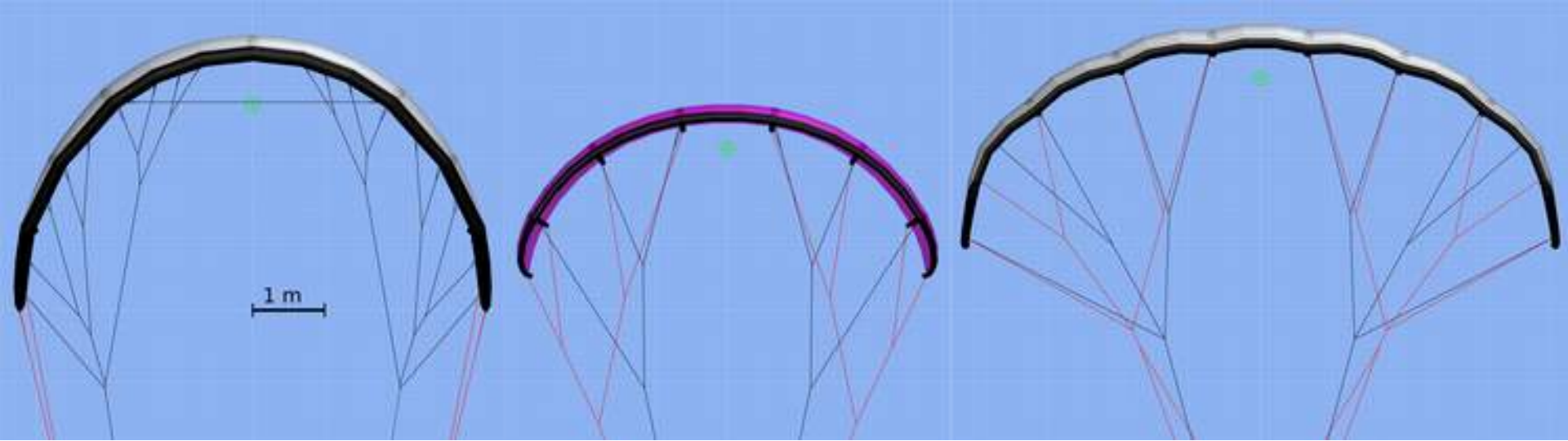

TU Delft V3 25 m<sup>2</sup>



Genetrix Hydra 14 m<sup>2</sup>



TU Delft V3 25 m<sup>2</sup>

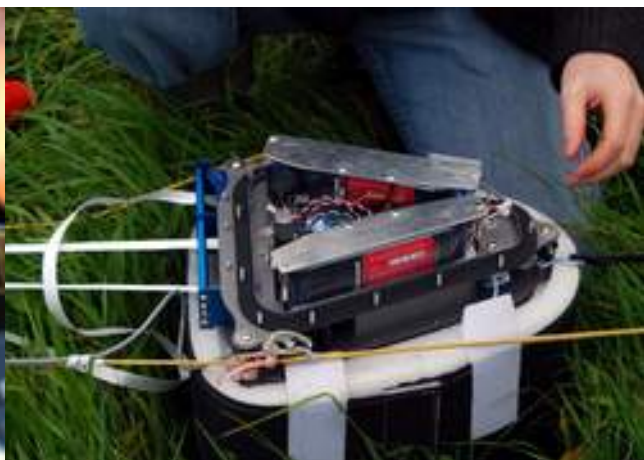
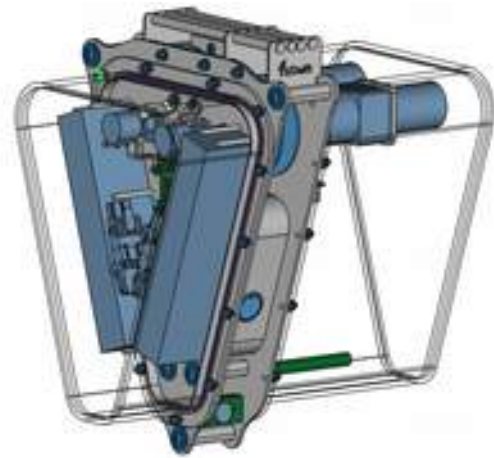
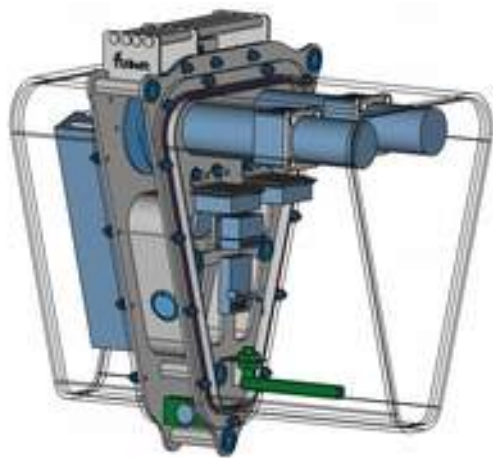
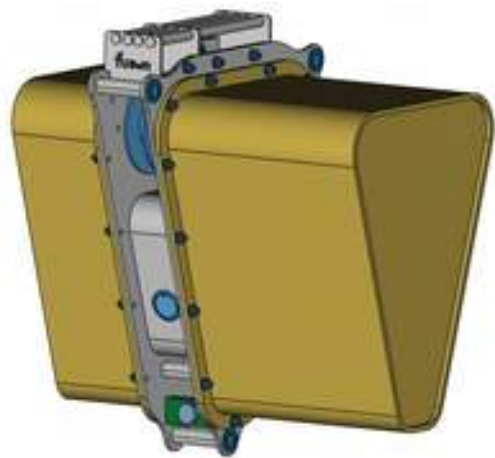

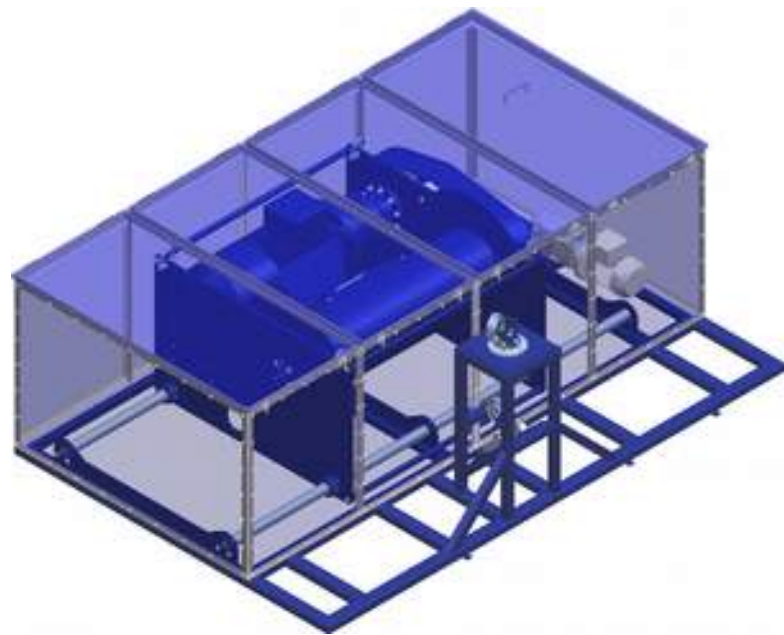
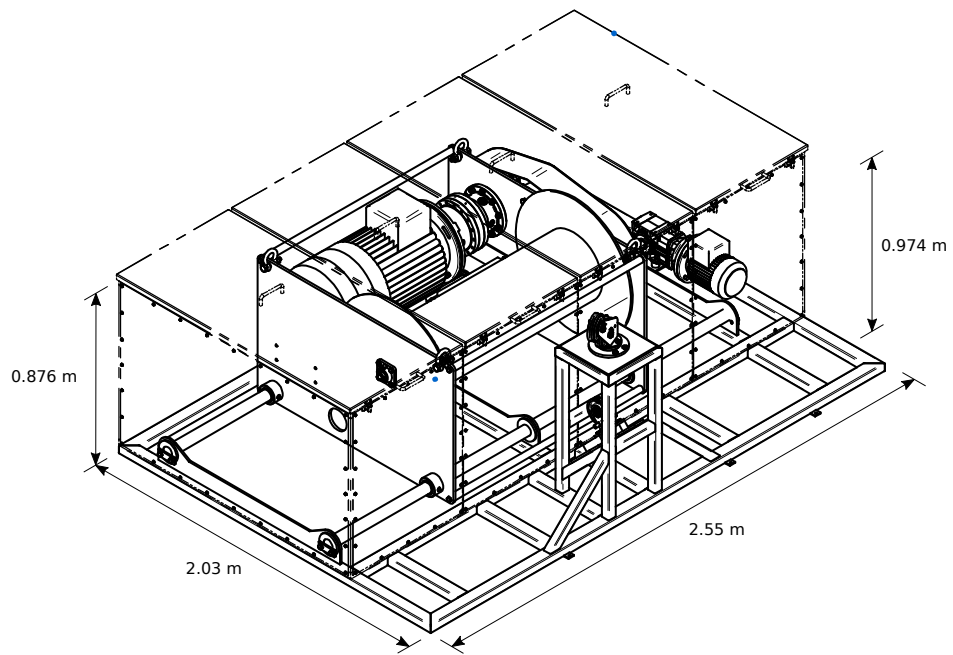

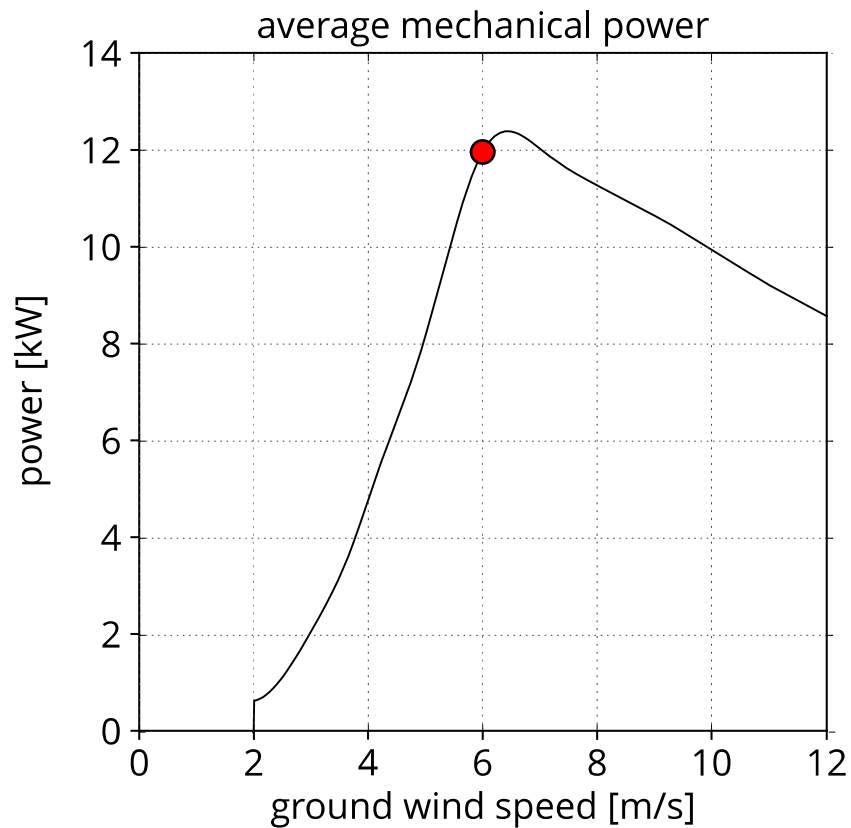
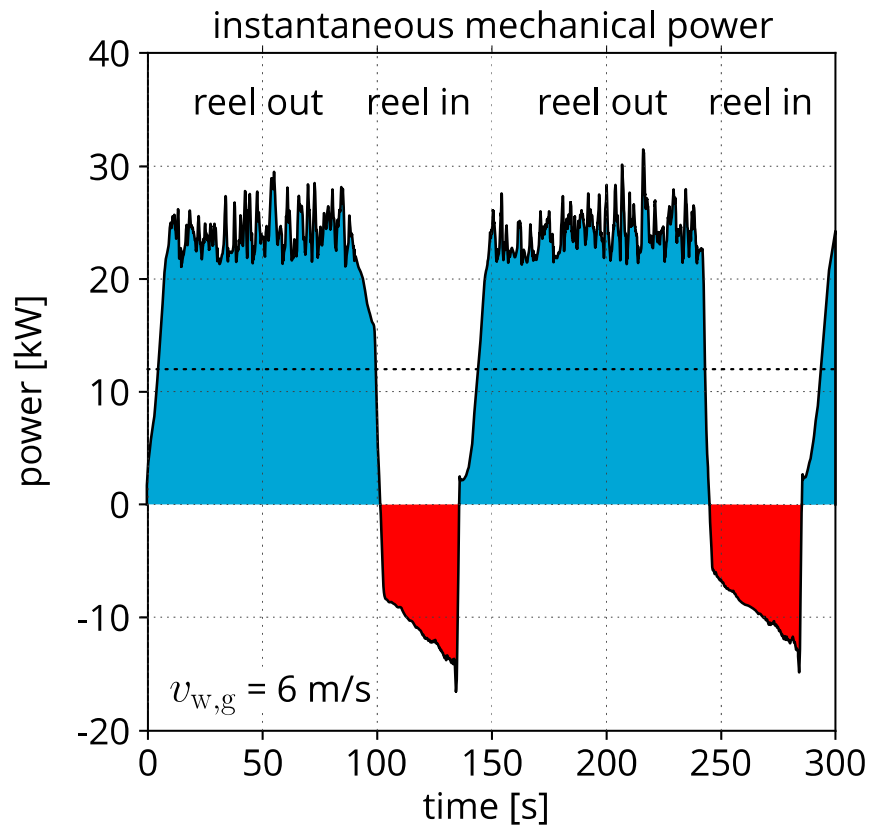

Automatic pumping cycles at Maasvlakte II of Rotterdam Harbor



# Kite Power 2.0 (2014-15)











40 m<sup>2</sup> kite

airborne wind energy  
**KITEPOWER**

2017



# 100 kW ground station



airborne wind energy  
**KITEPOWER**





airborne wind energy

KITEPOWER





KITEPOWER™









**Kite development: 25 – 40 – 60 m<sup>2</sup>**



**Kite development: 100 m<sup>2</sup>**





airborne wind energy

**KITEPOWER**





# Flight days

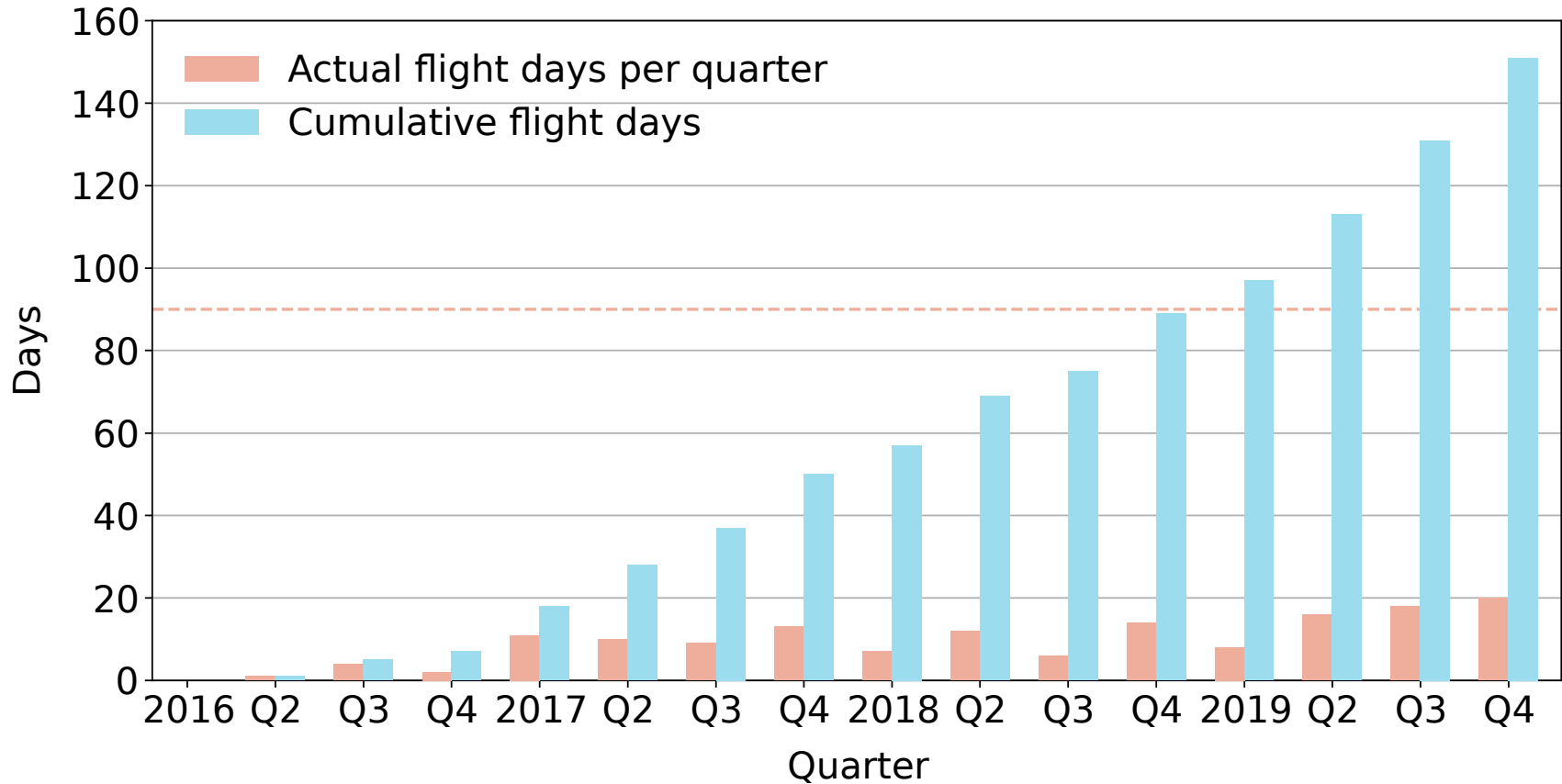

# Development as an industry

number of institutions involved in AWE

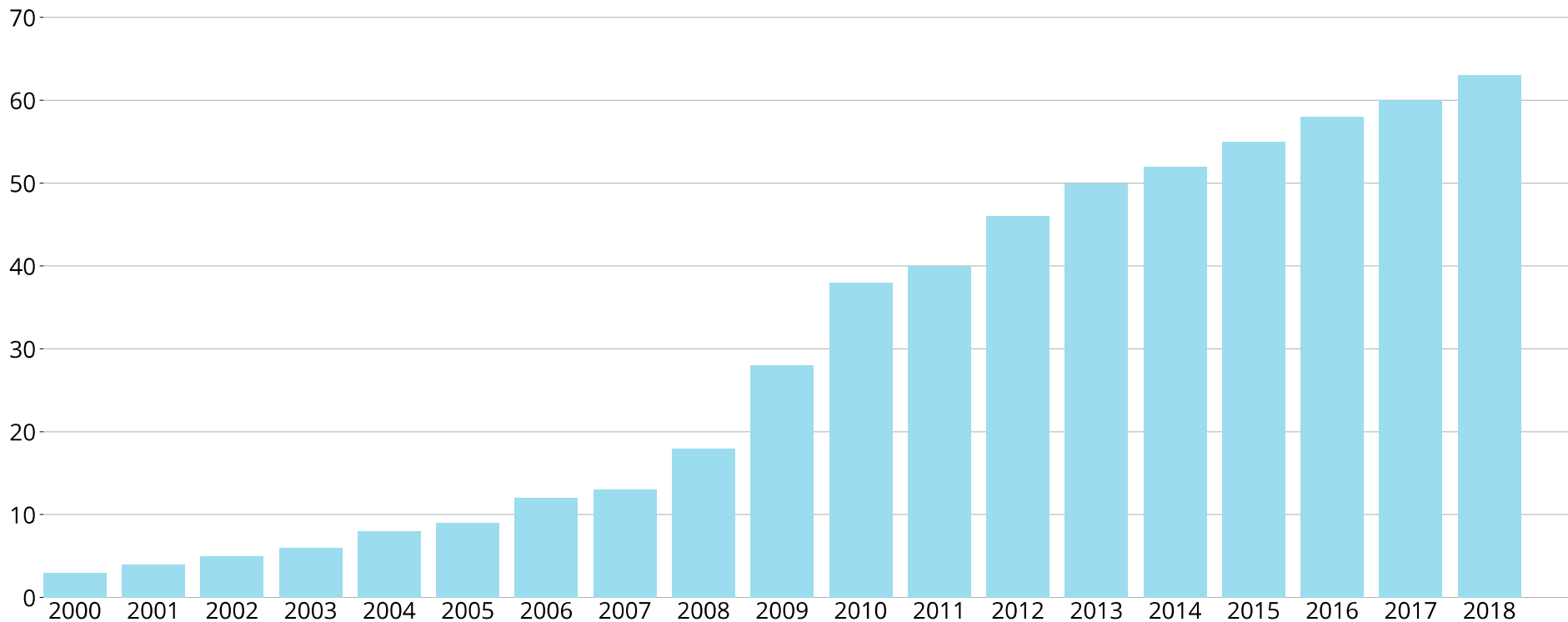



# R&D landscape 2018



academia  
industry

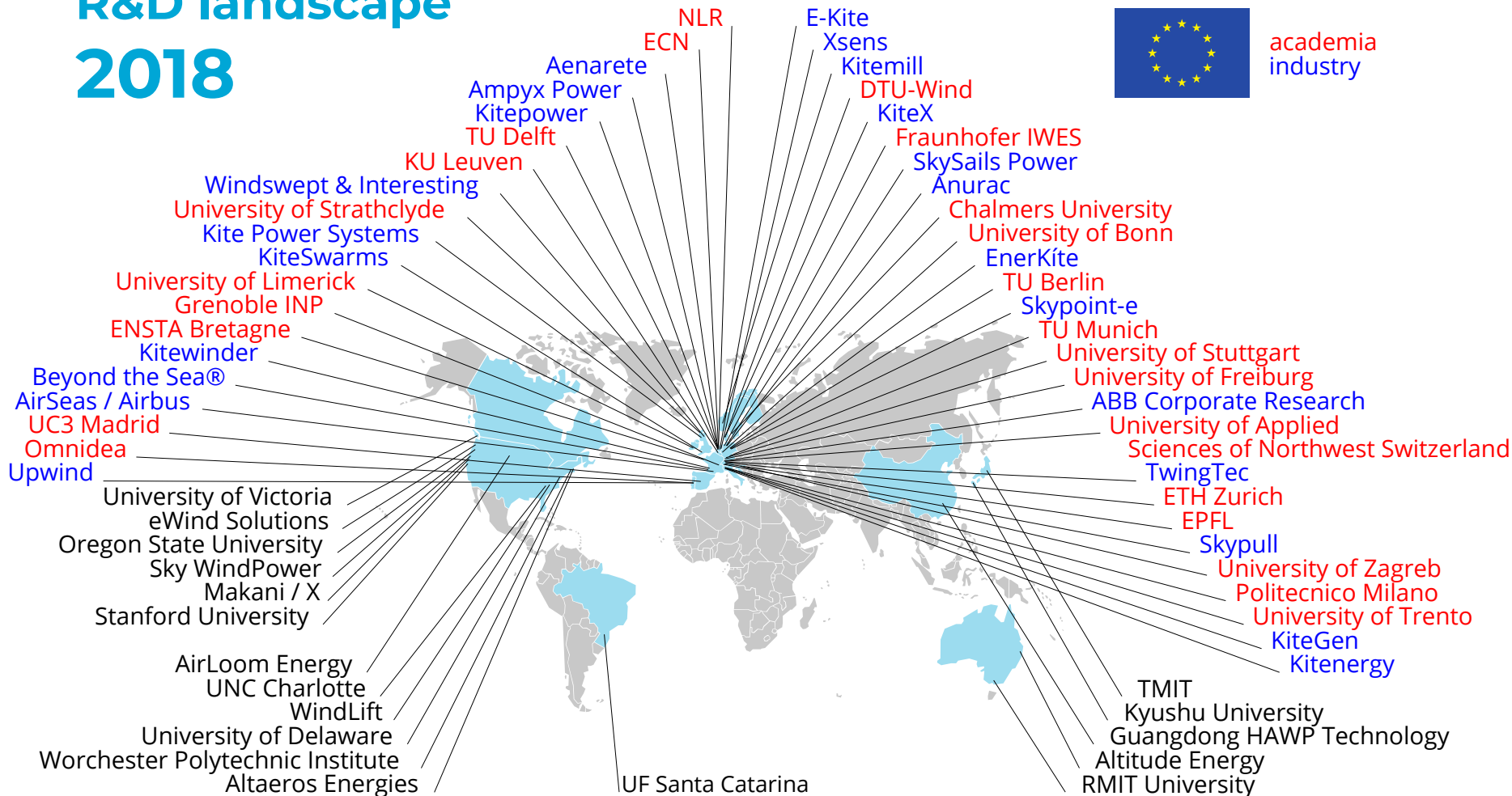

# Challenges

- Reliability & Safety
  - None of the projects has proven more than a few days of operation
  - Operation in kite parks
- Durability of materials
  - Tether and kite are critical components
- Regulations
  - Interference with air traffic and ground use

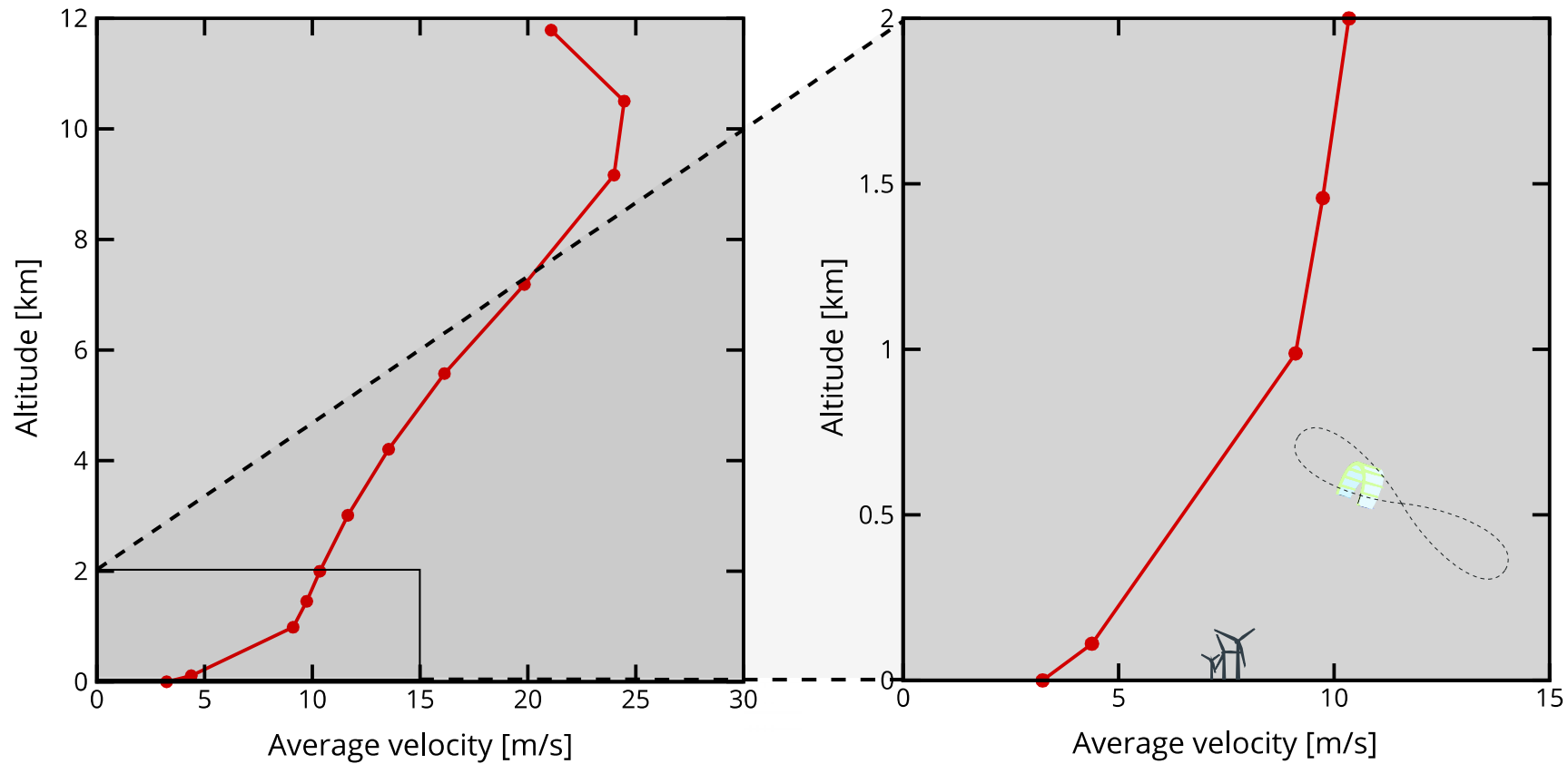

KNMI 20 year average wind data for De Bilt, the Netherlands.

# AWE resource assessment

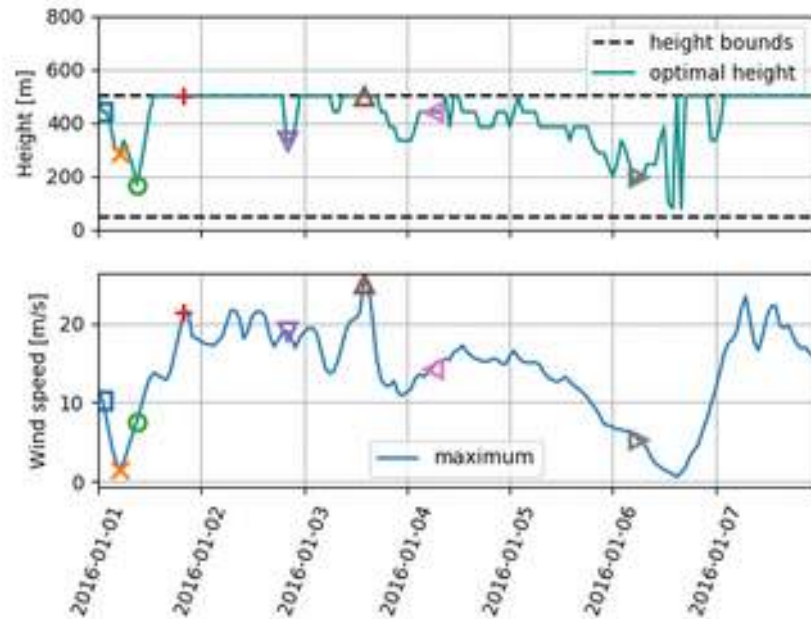
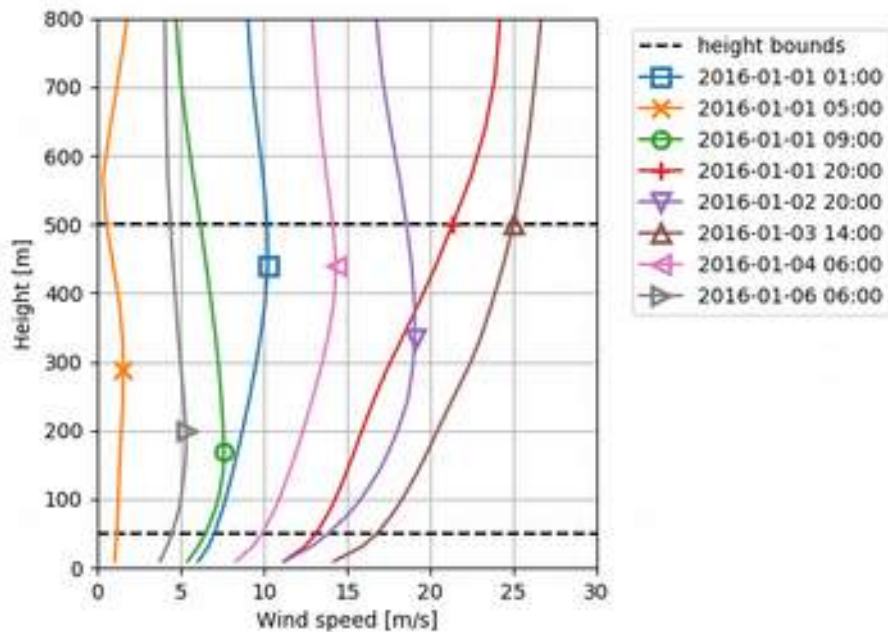

# VLM simulation

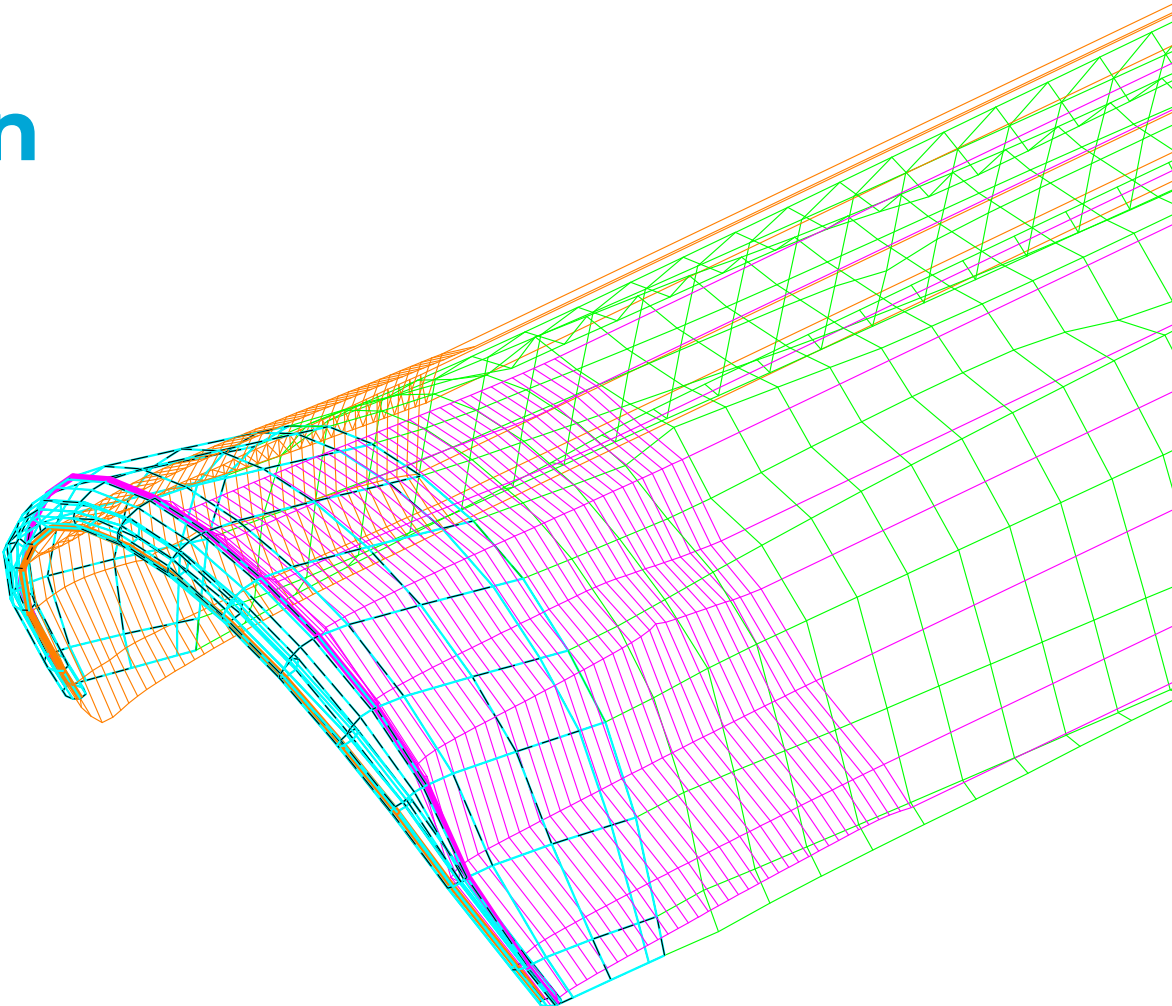

# CFD analysis

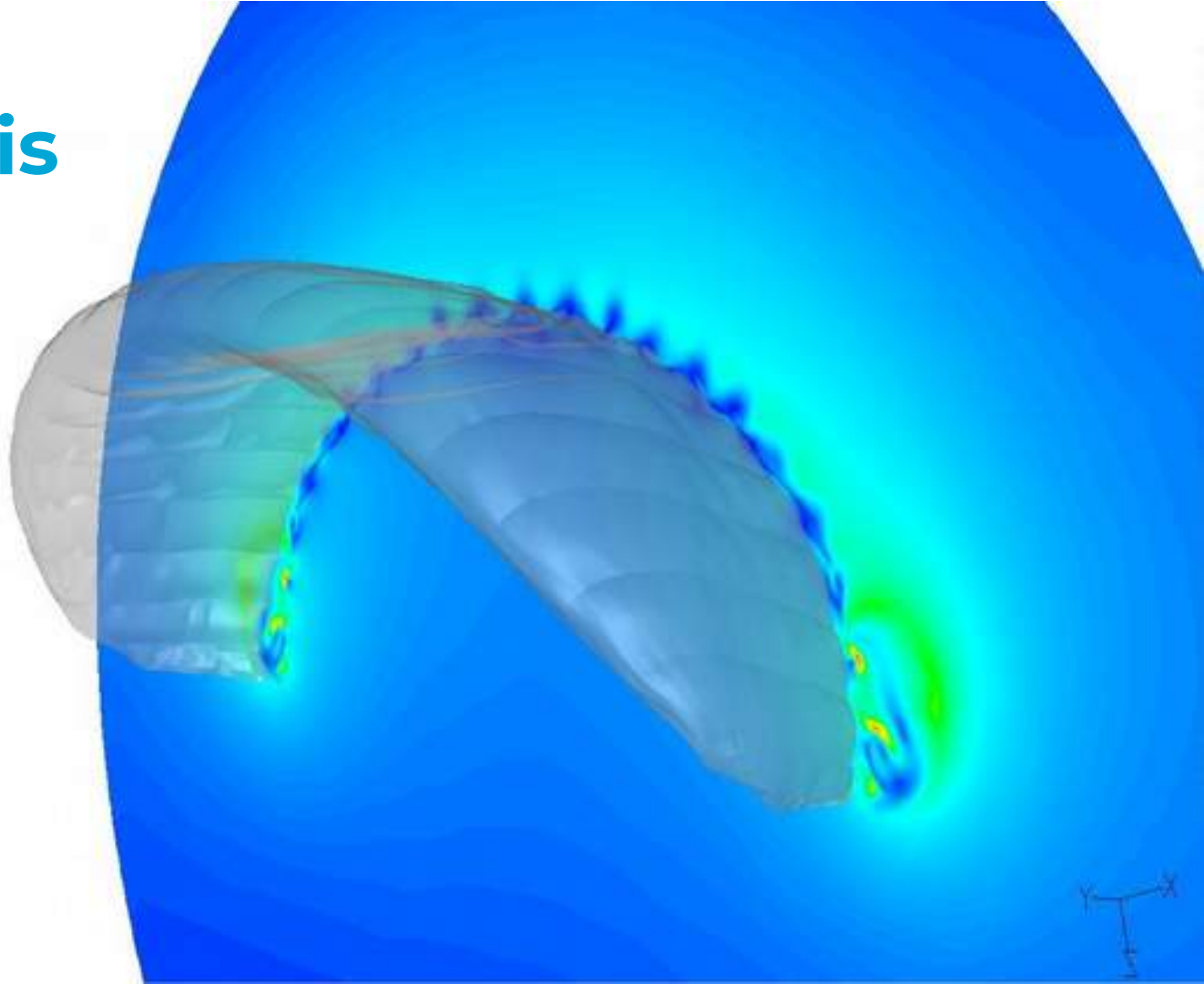

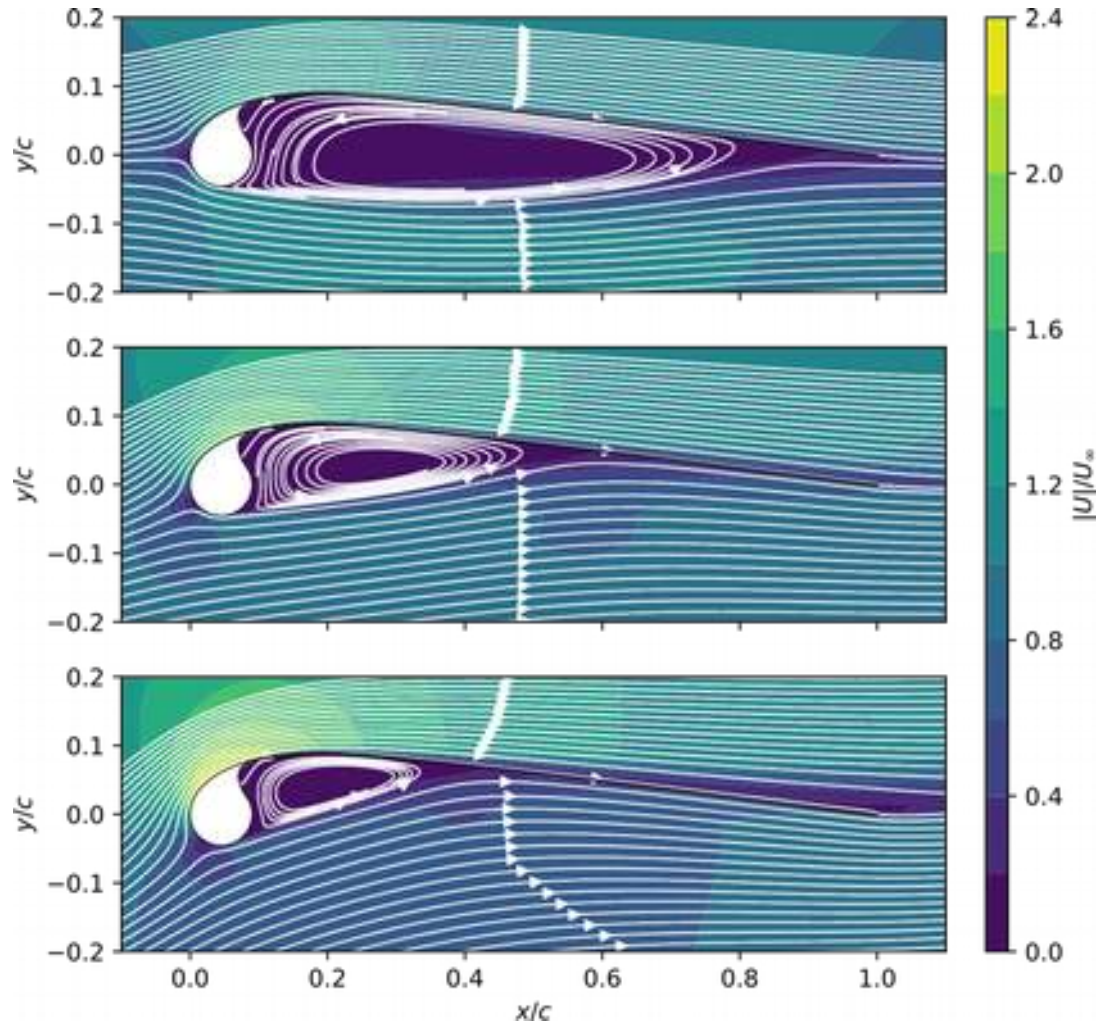

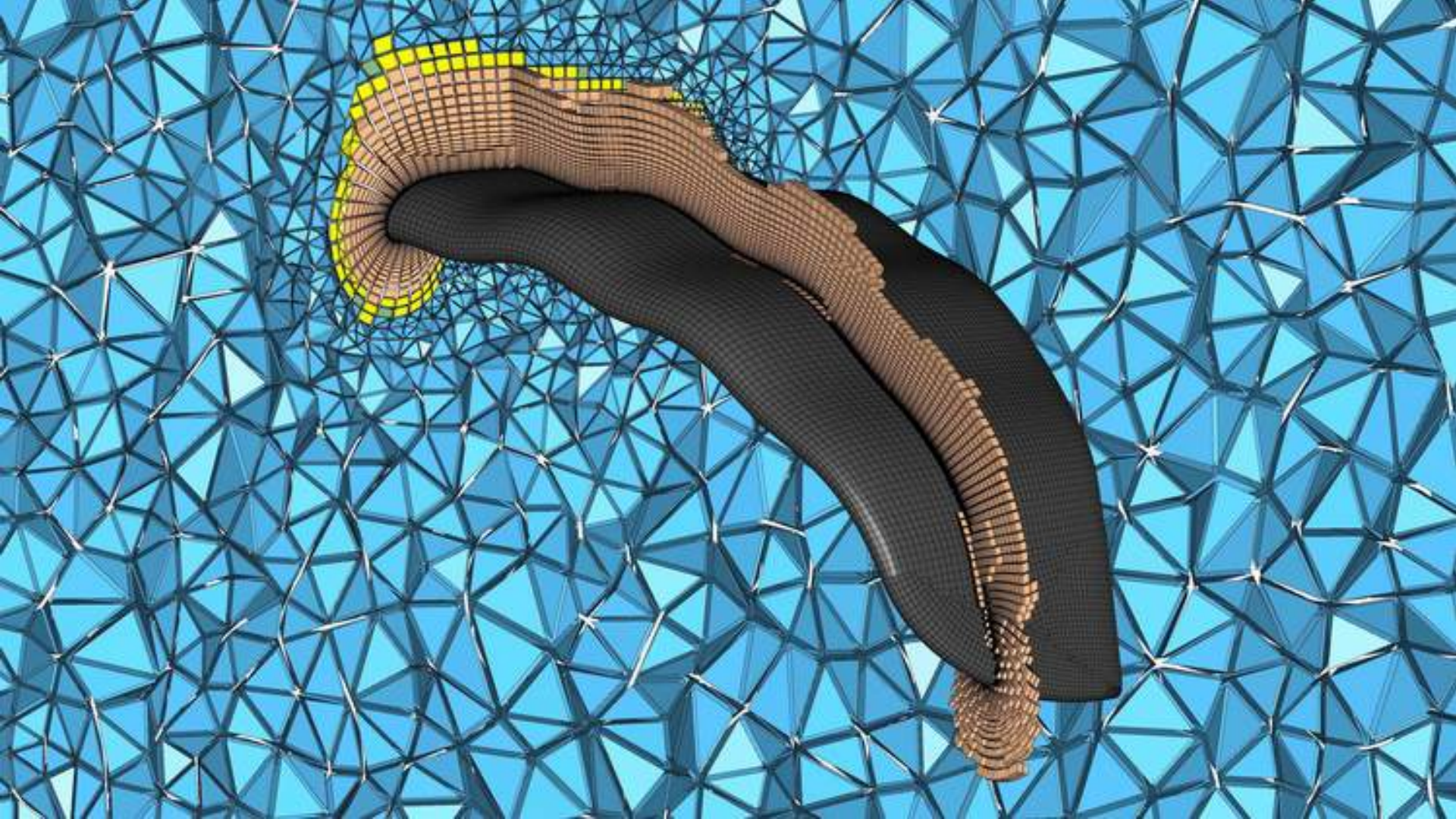



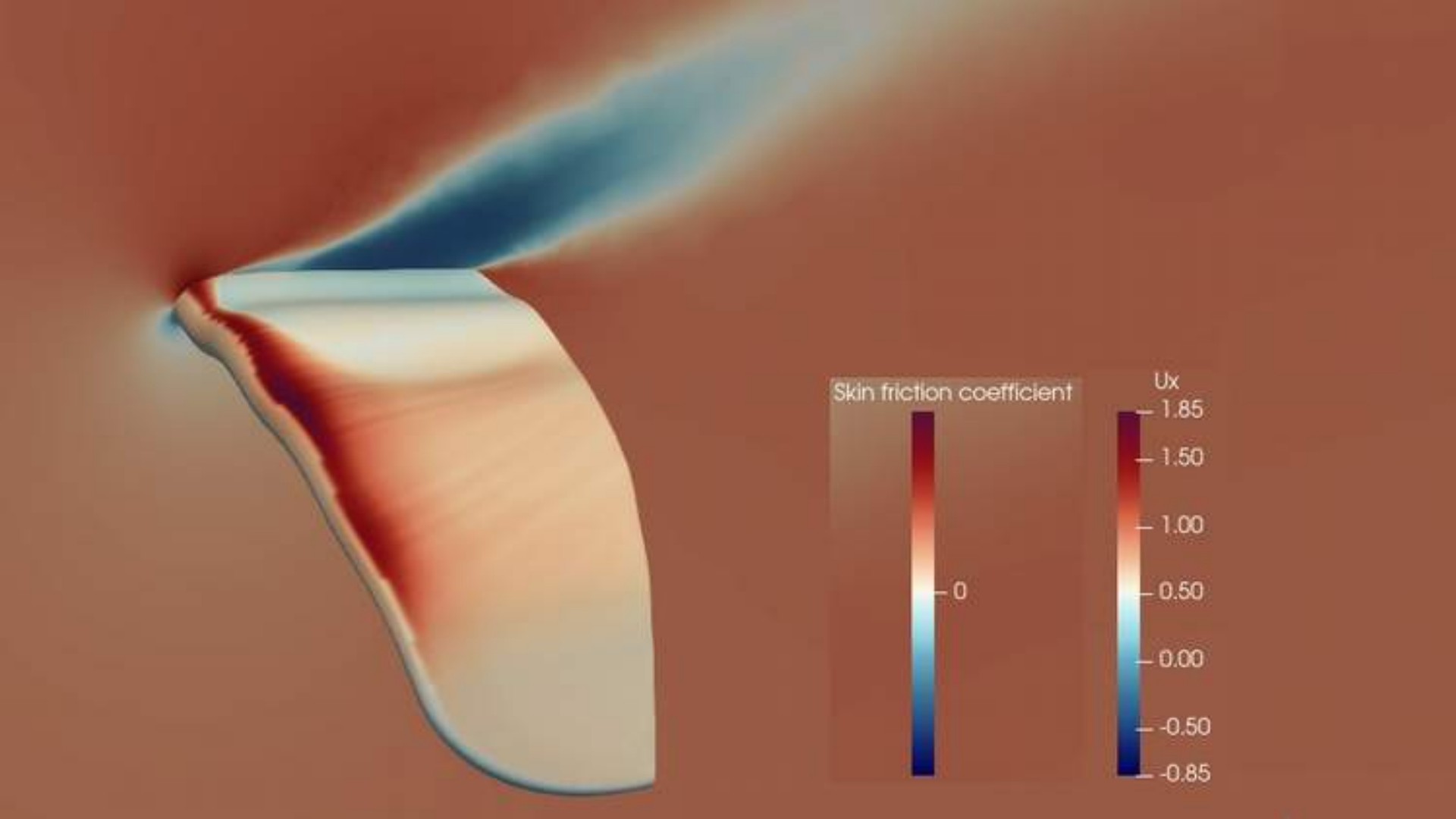

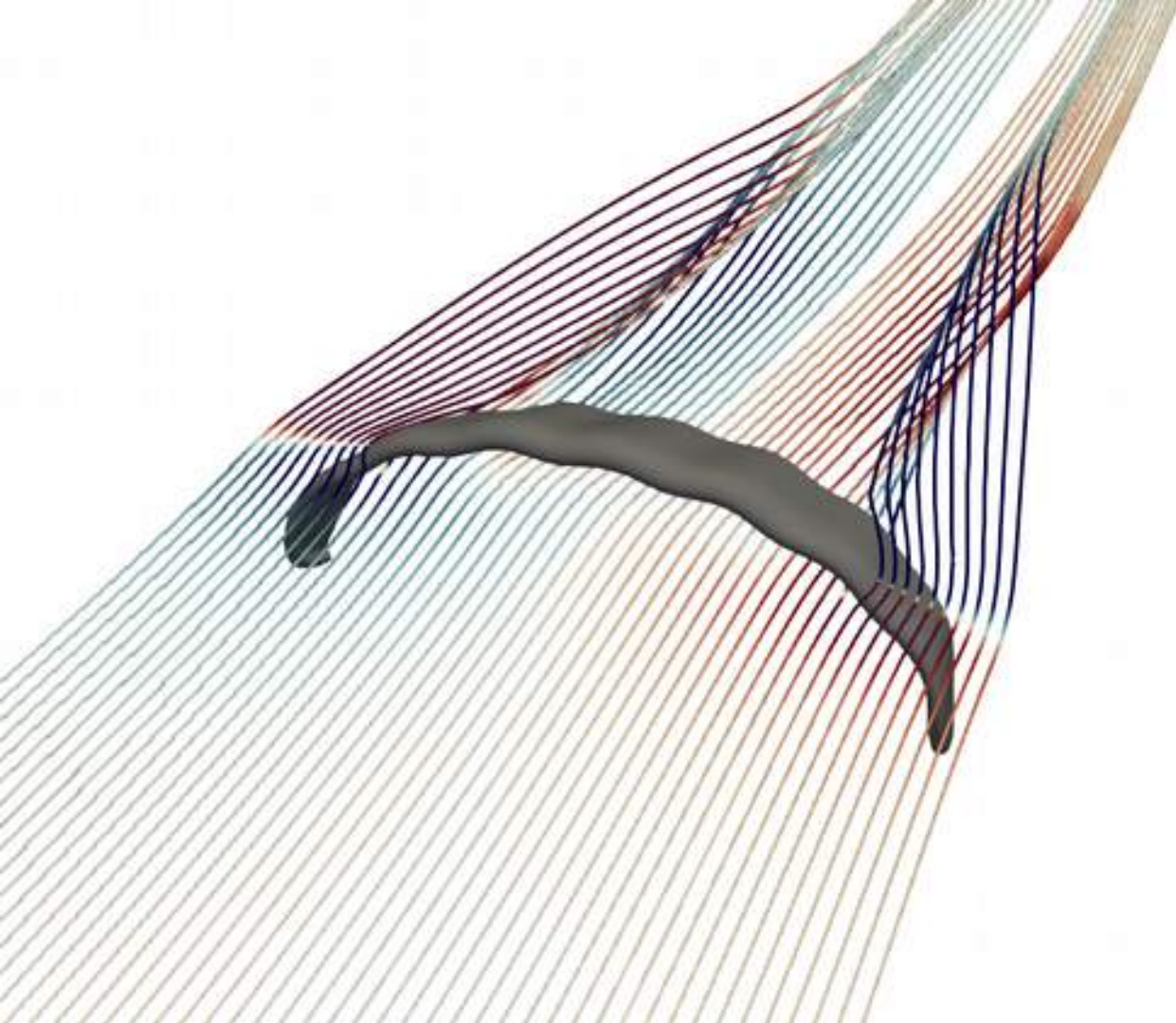

**CFD simulation with OpenFOAM**  
Streamlines around the kite colored  
With the spanwise velocity component,  
computed for  $Re=3 \times 10^6$  and  $12^\circ$  AoA

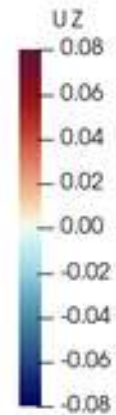

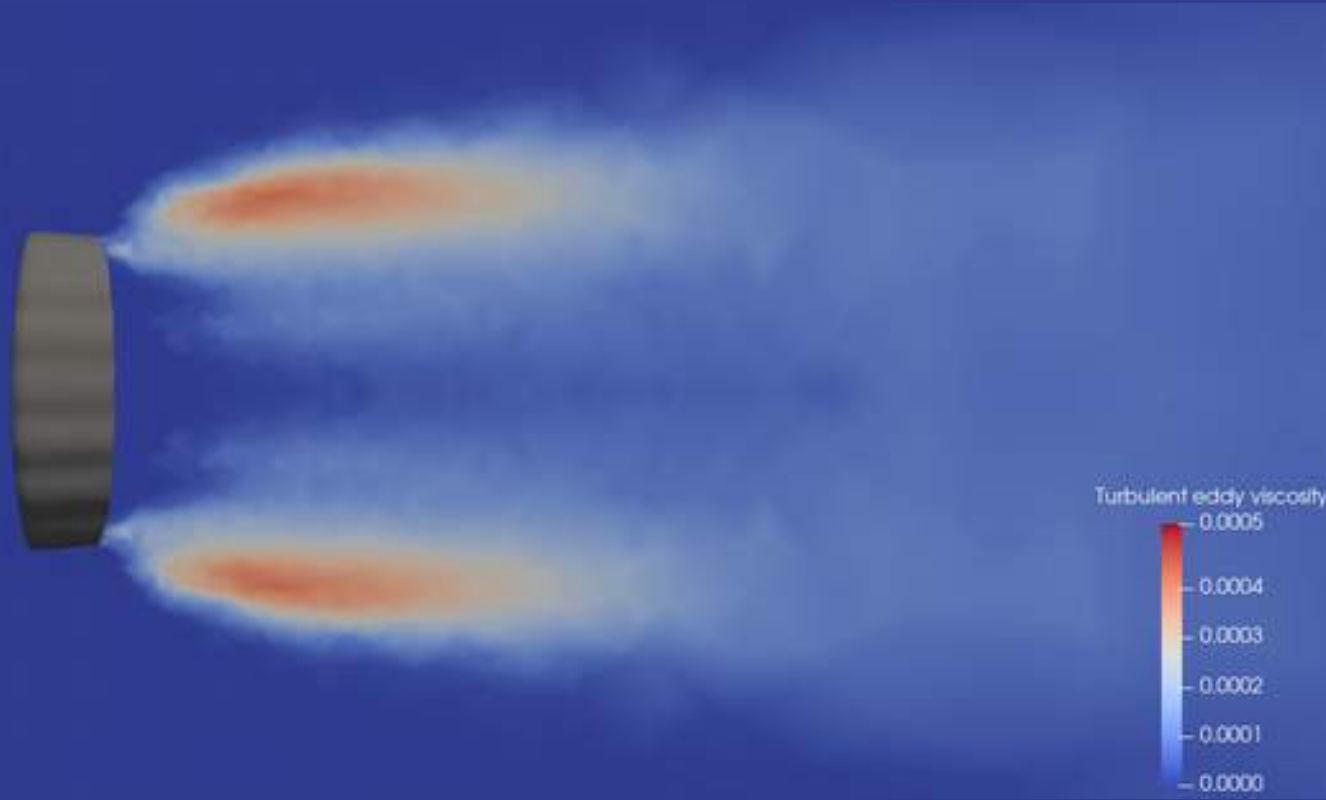

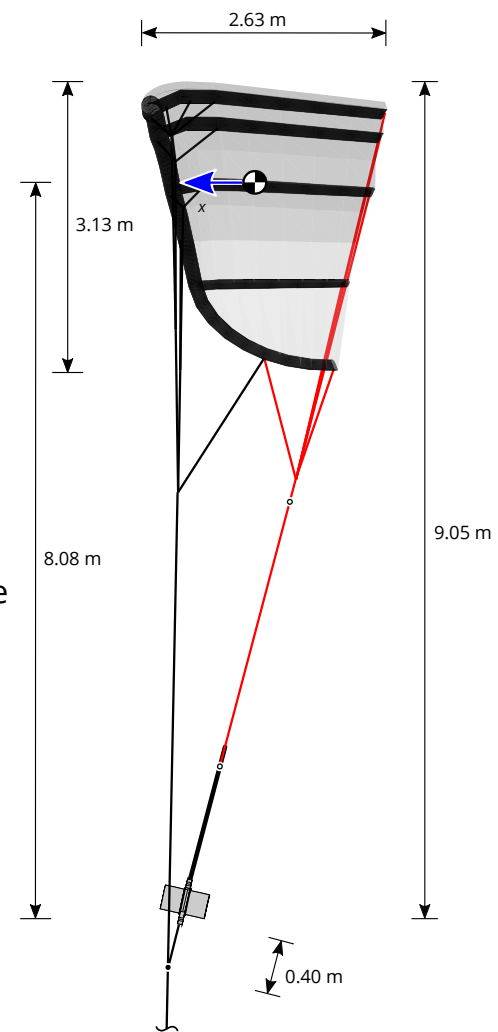
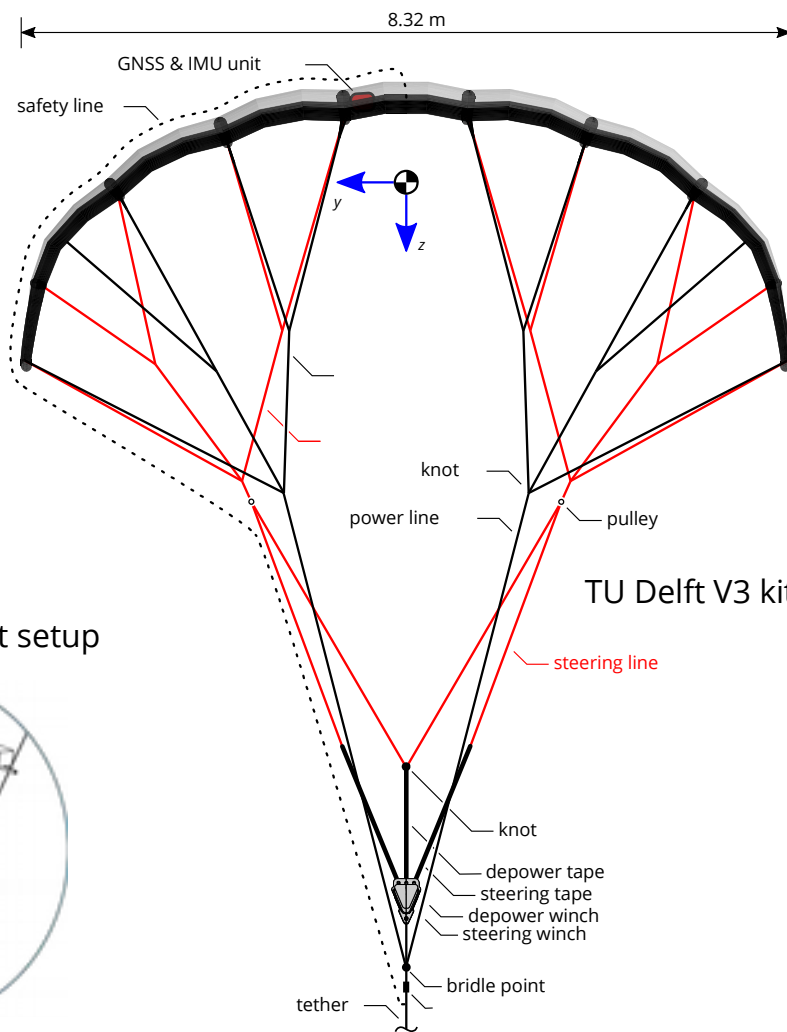

### Relative flow measurement setup

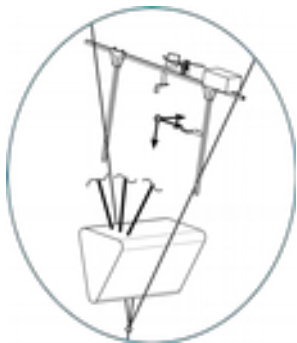

# Effect of power

- Changes chordwise force distribution
- Powering up the wing makes wing pitch backwards

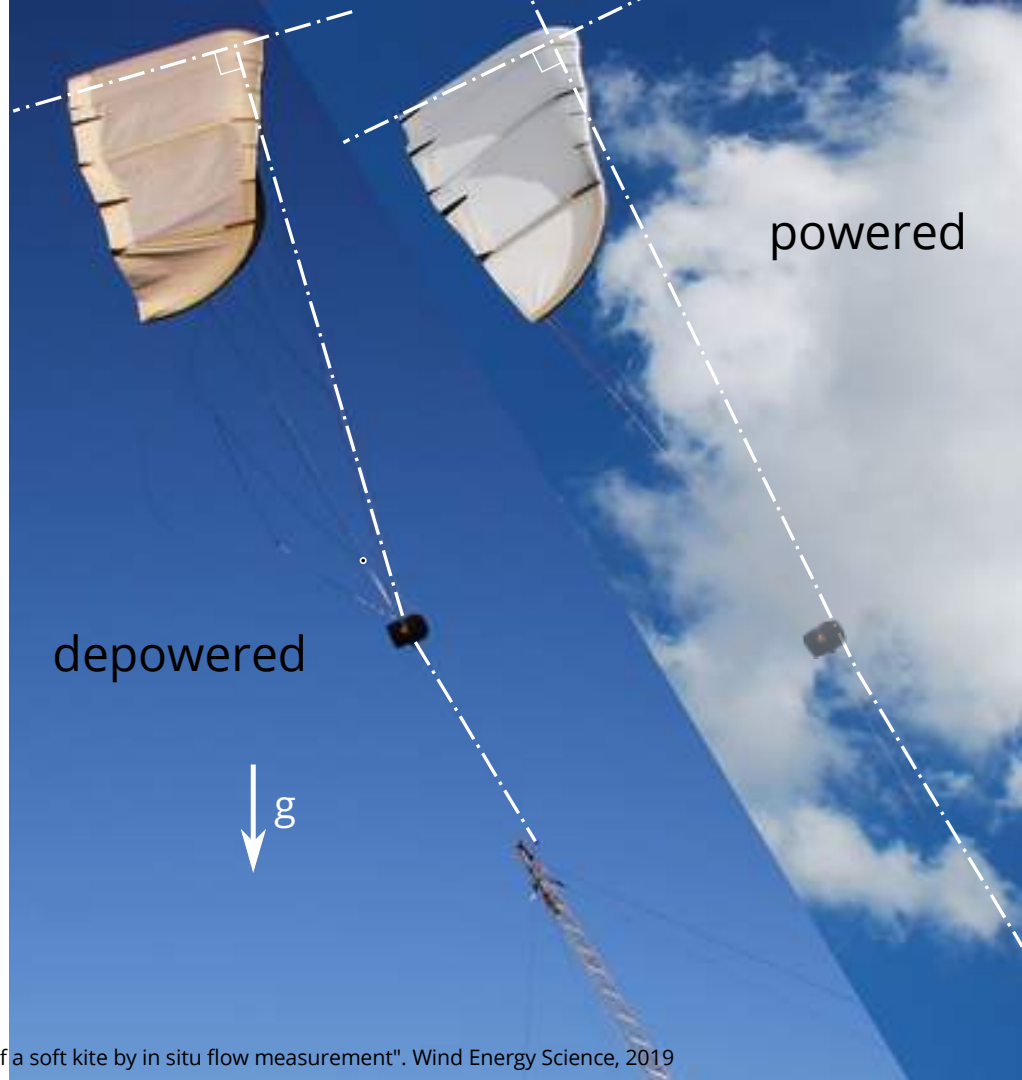

# Effect of power

- Wing flattens
- Force increase also by area increase



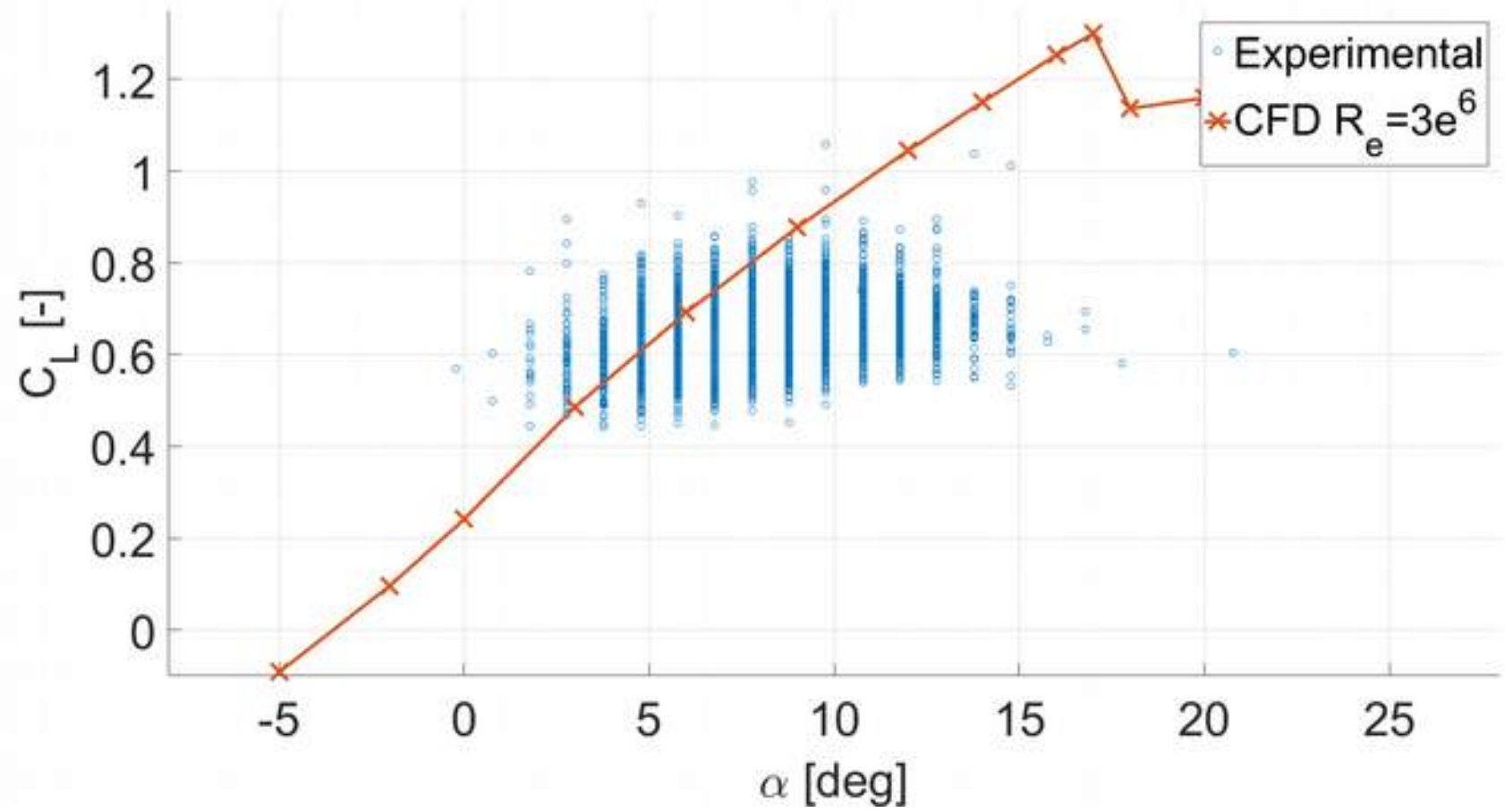

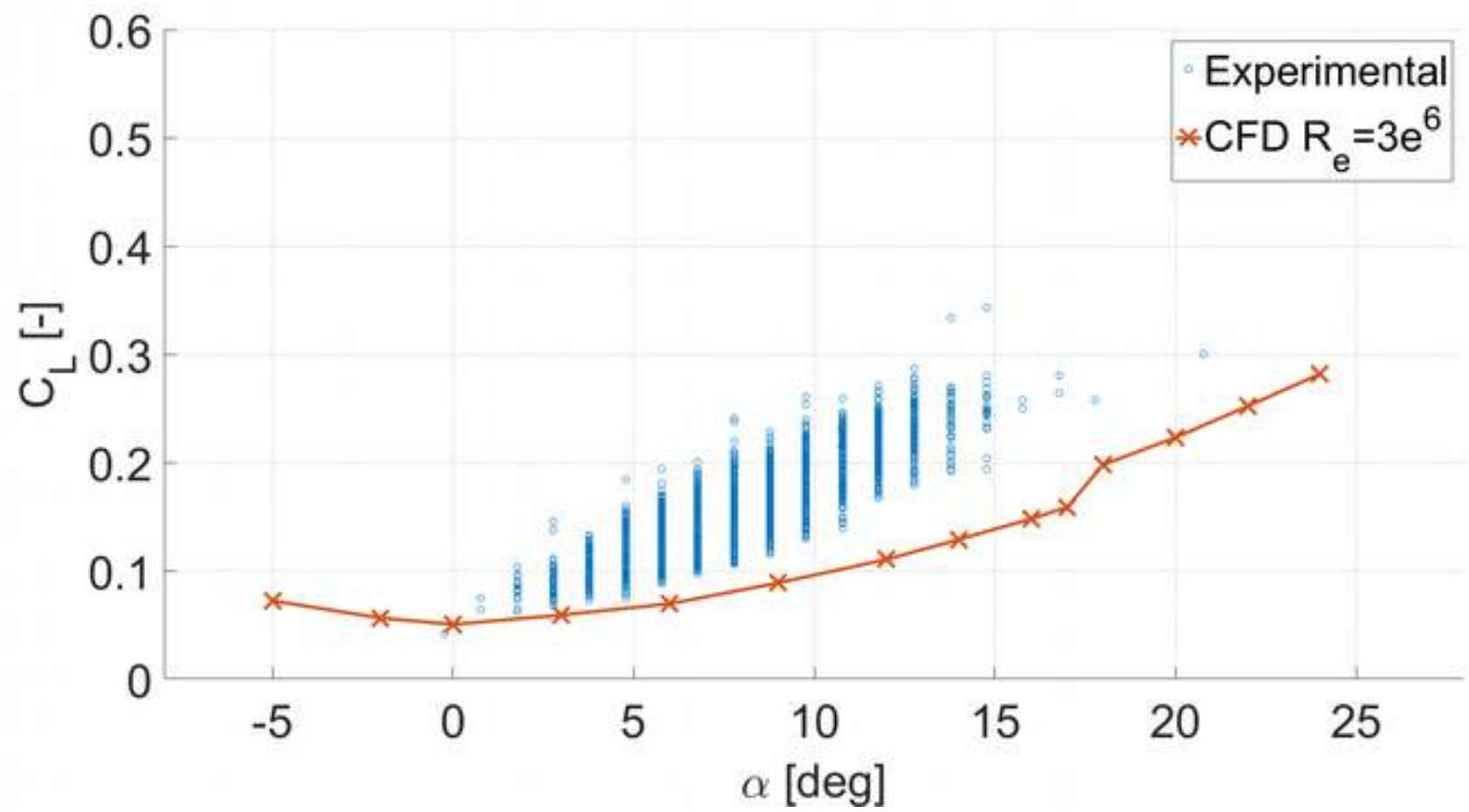



# Aerodynamics

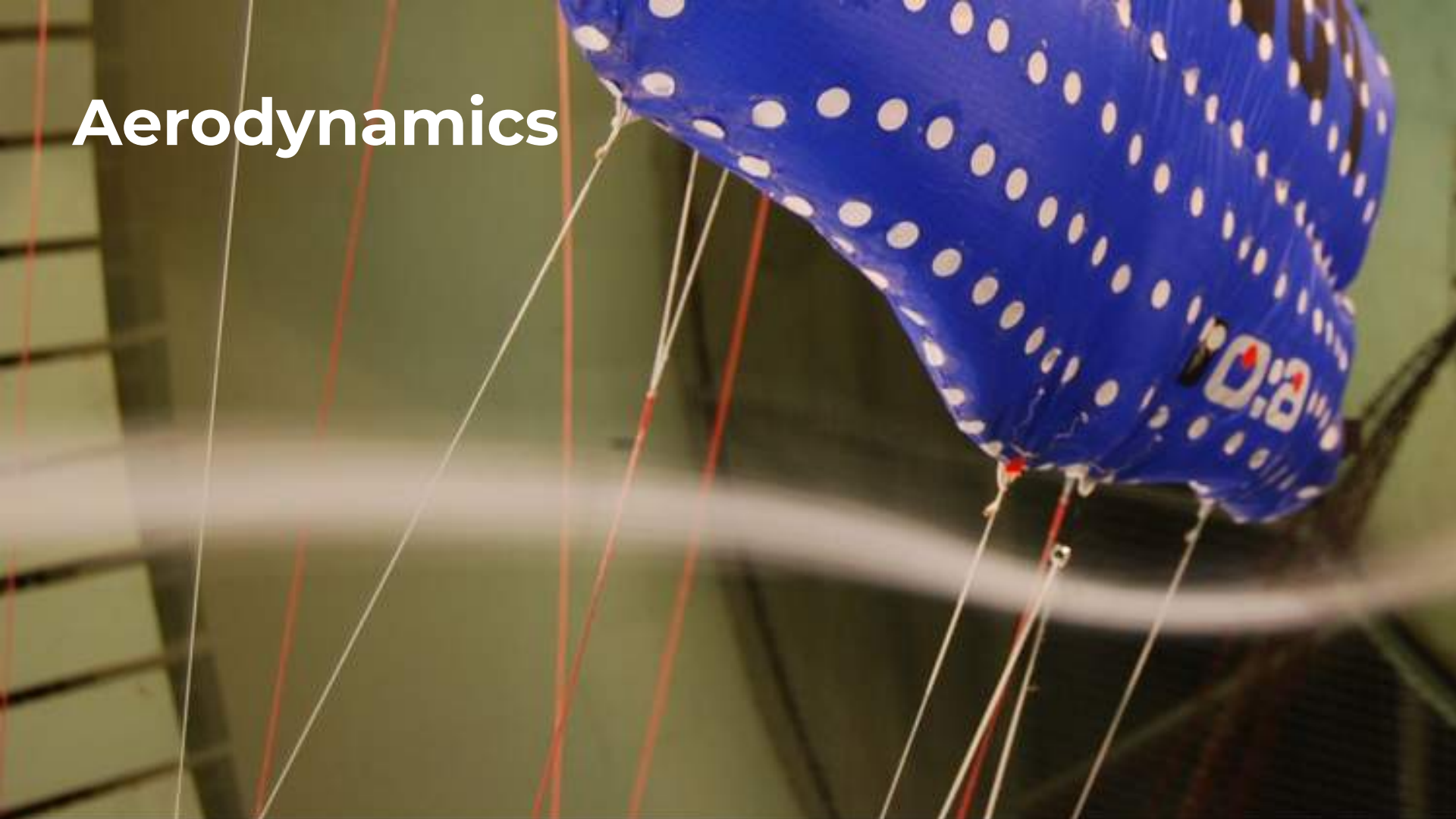

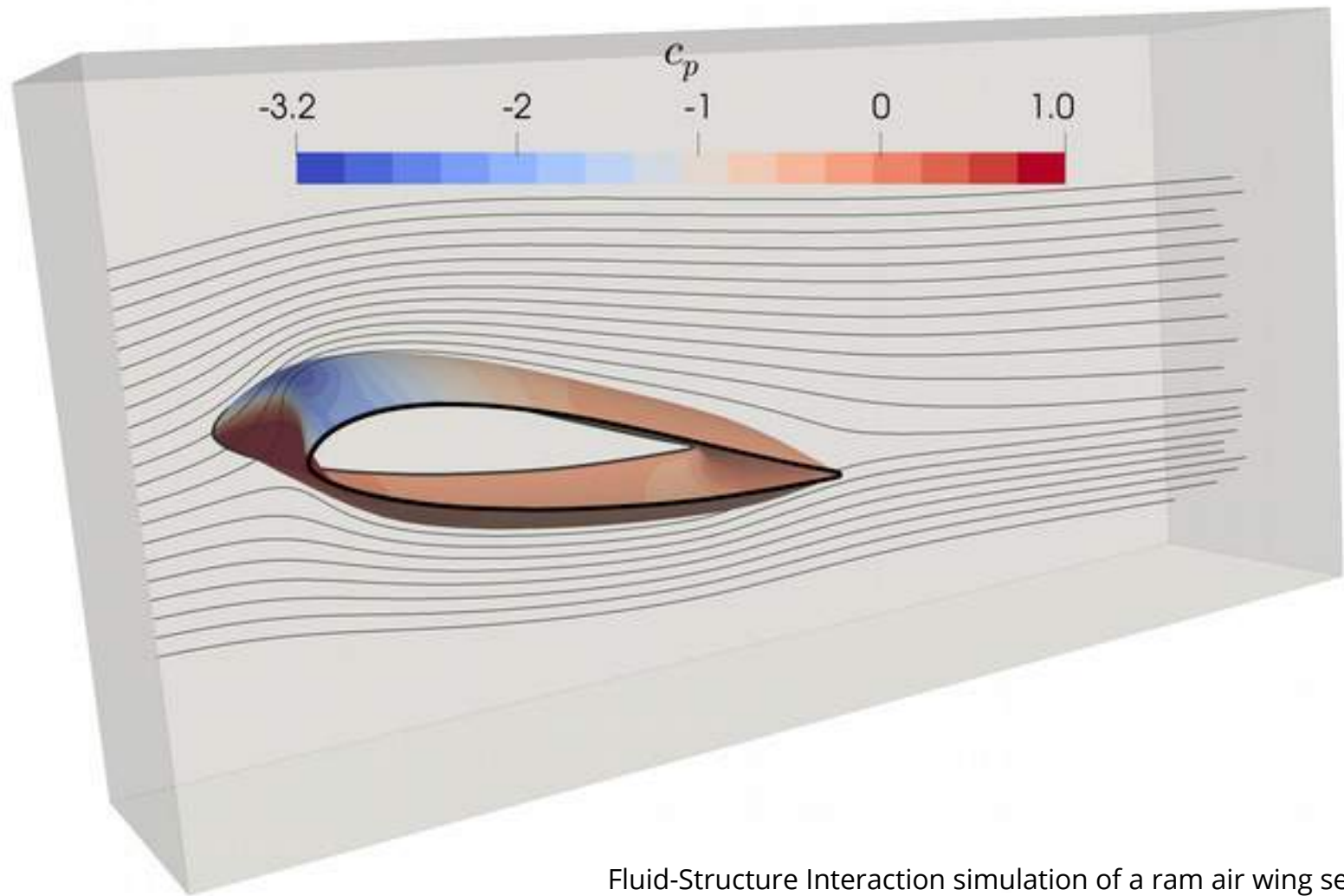

Fluid-Structure Interaction simulation of a ram air wing section

Finite element model of a LEI kite

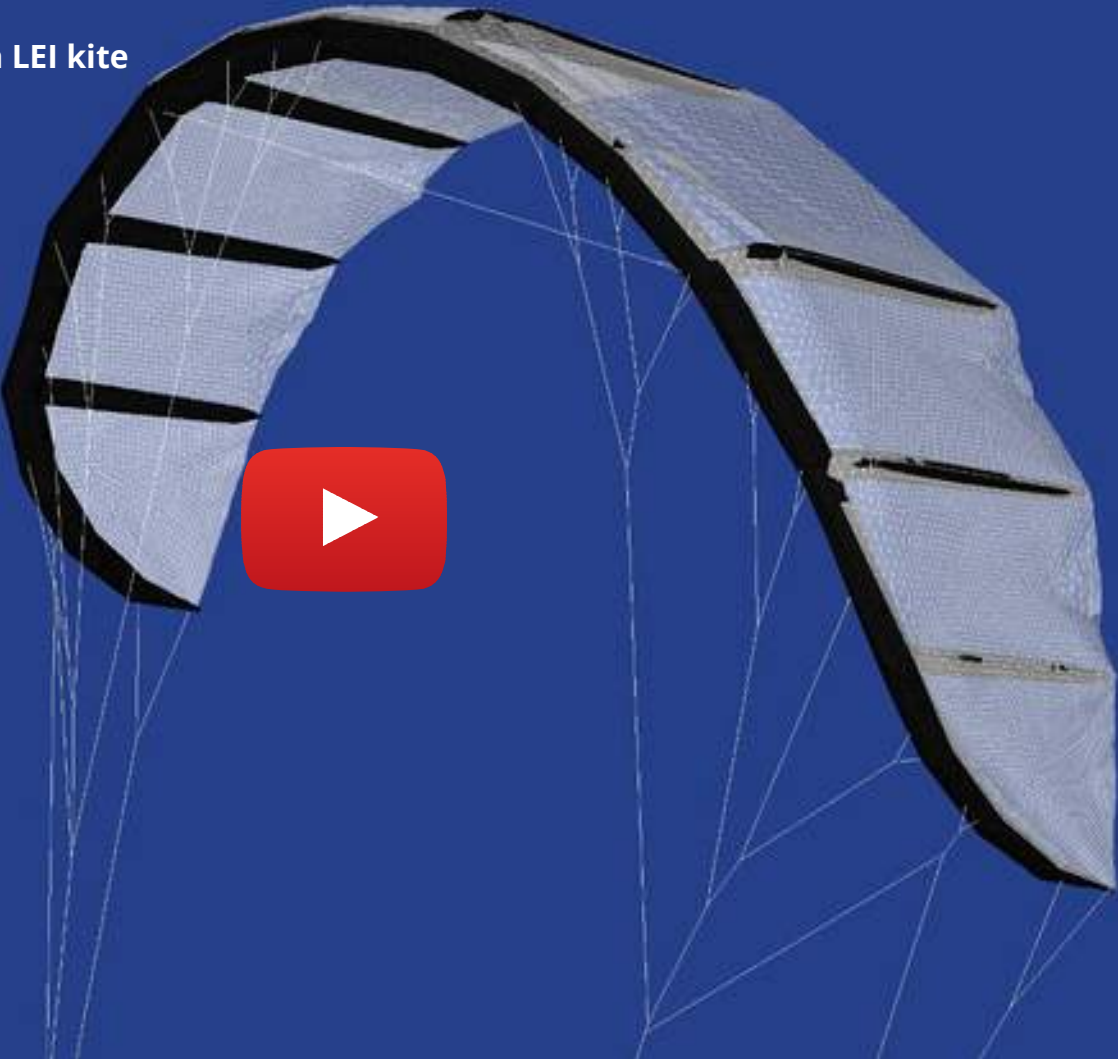

# Aeroelastic bending and torsion of a half wing supported by a bridle line

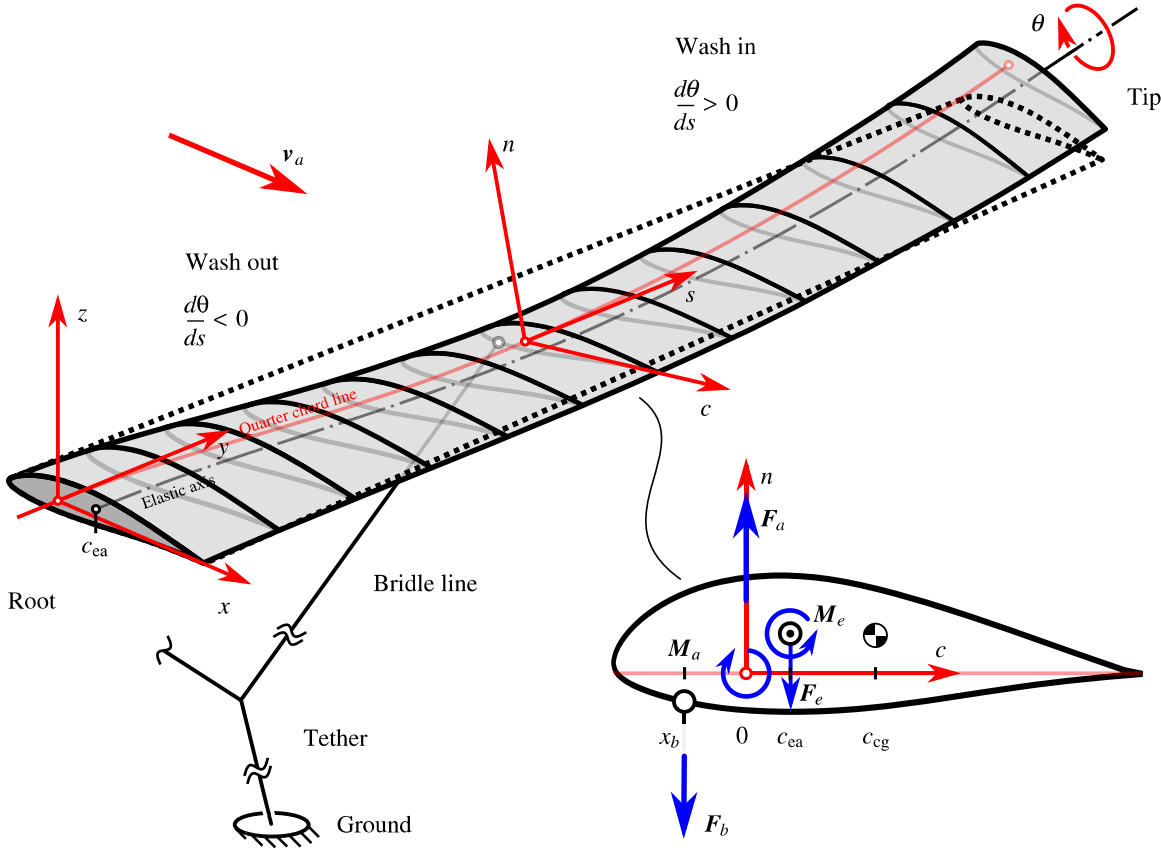

# Aeroelastic model of an AWT and the tensile support system connecting it to the ground

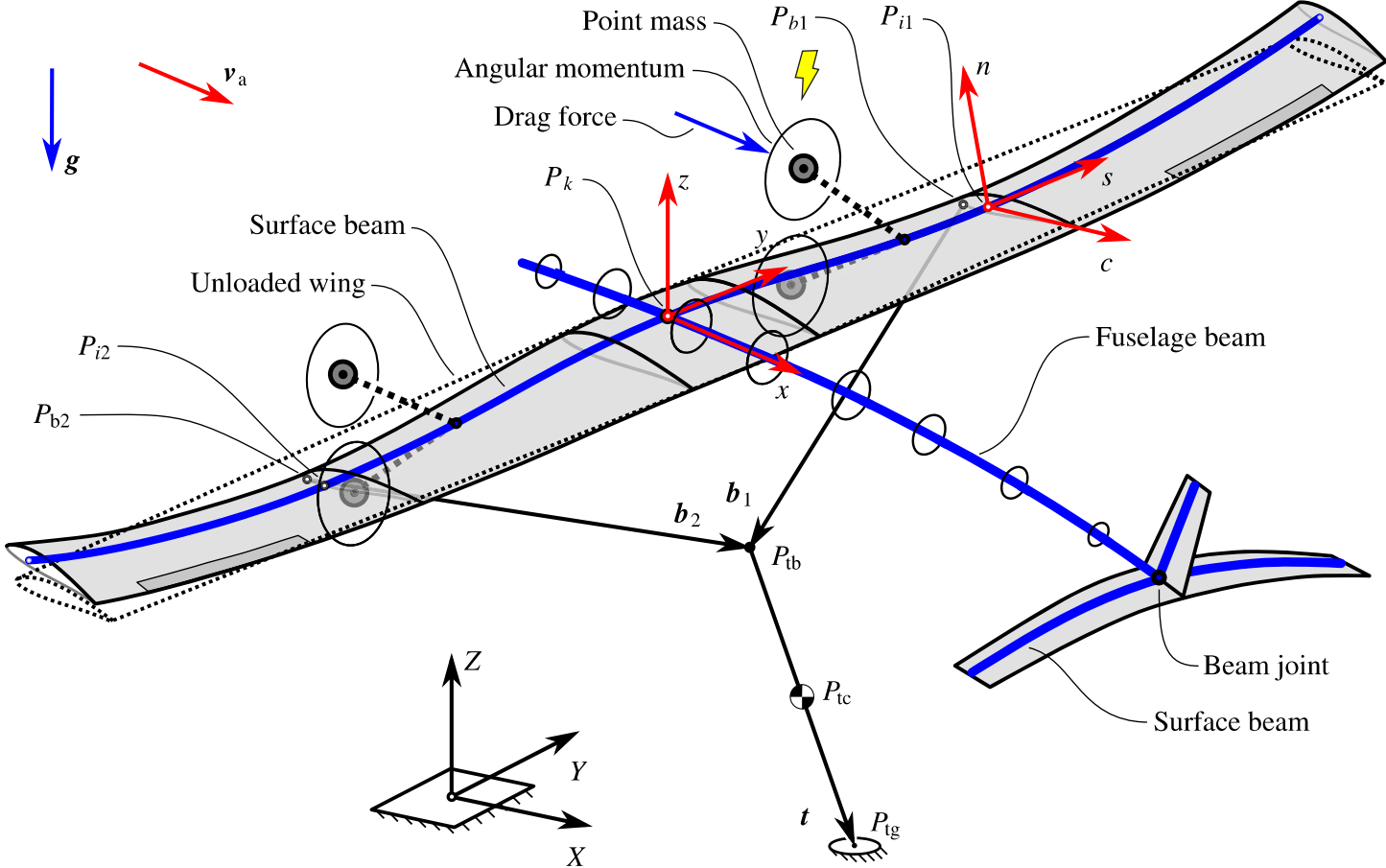

Bridle line forces in a swept wing

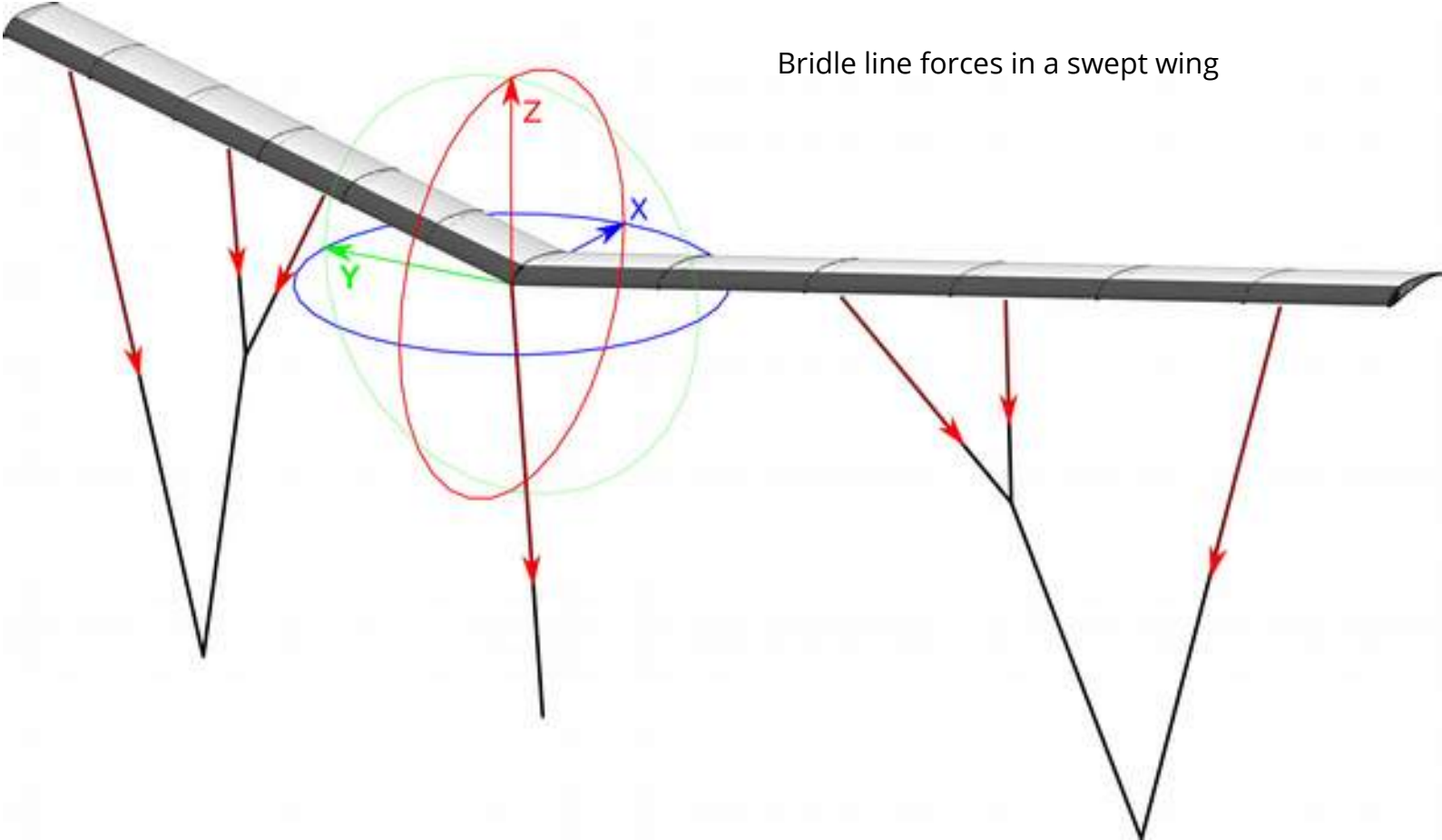

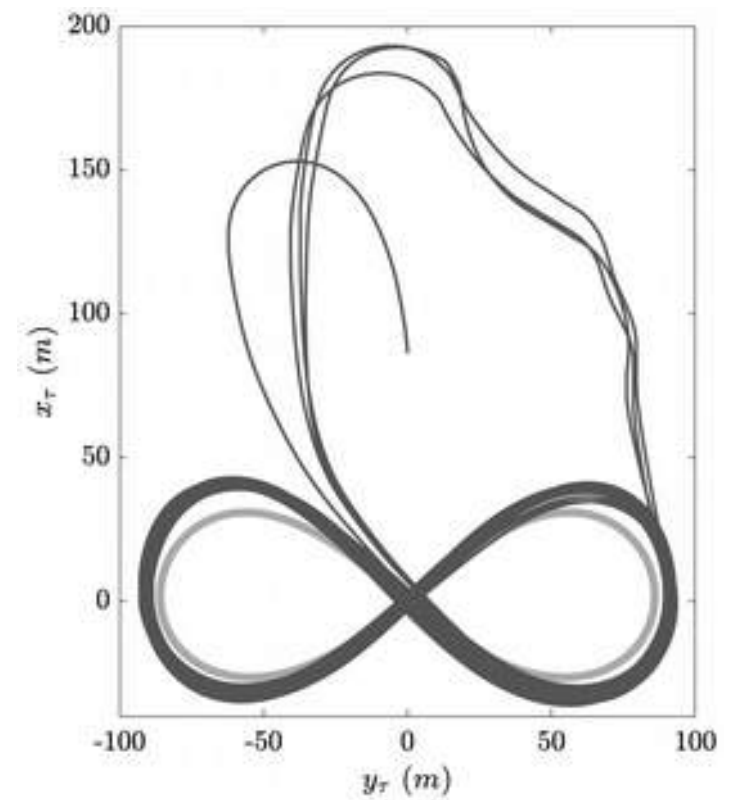
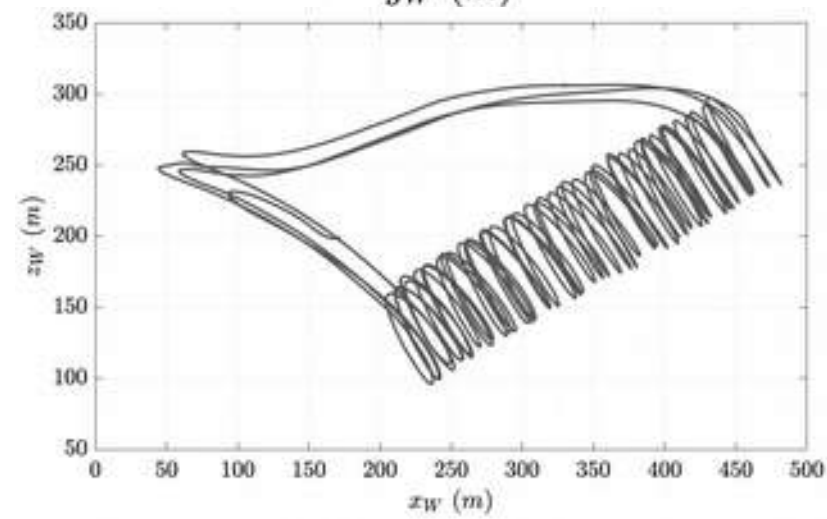
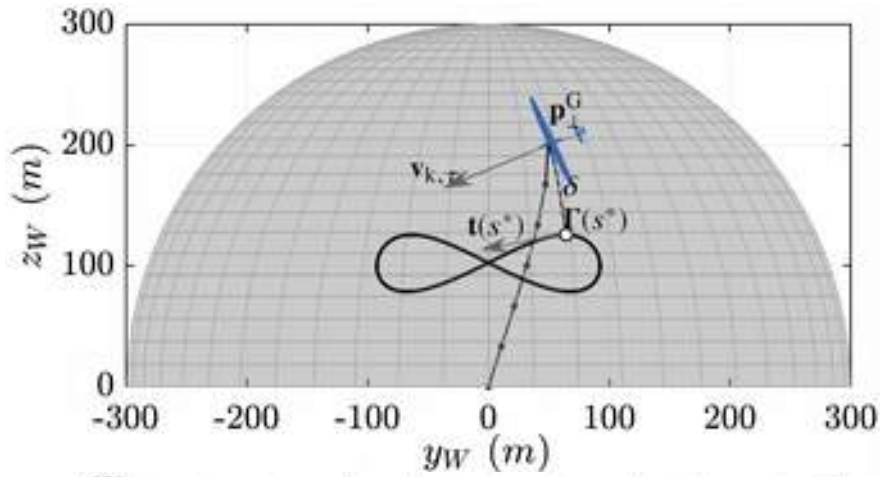

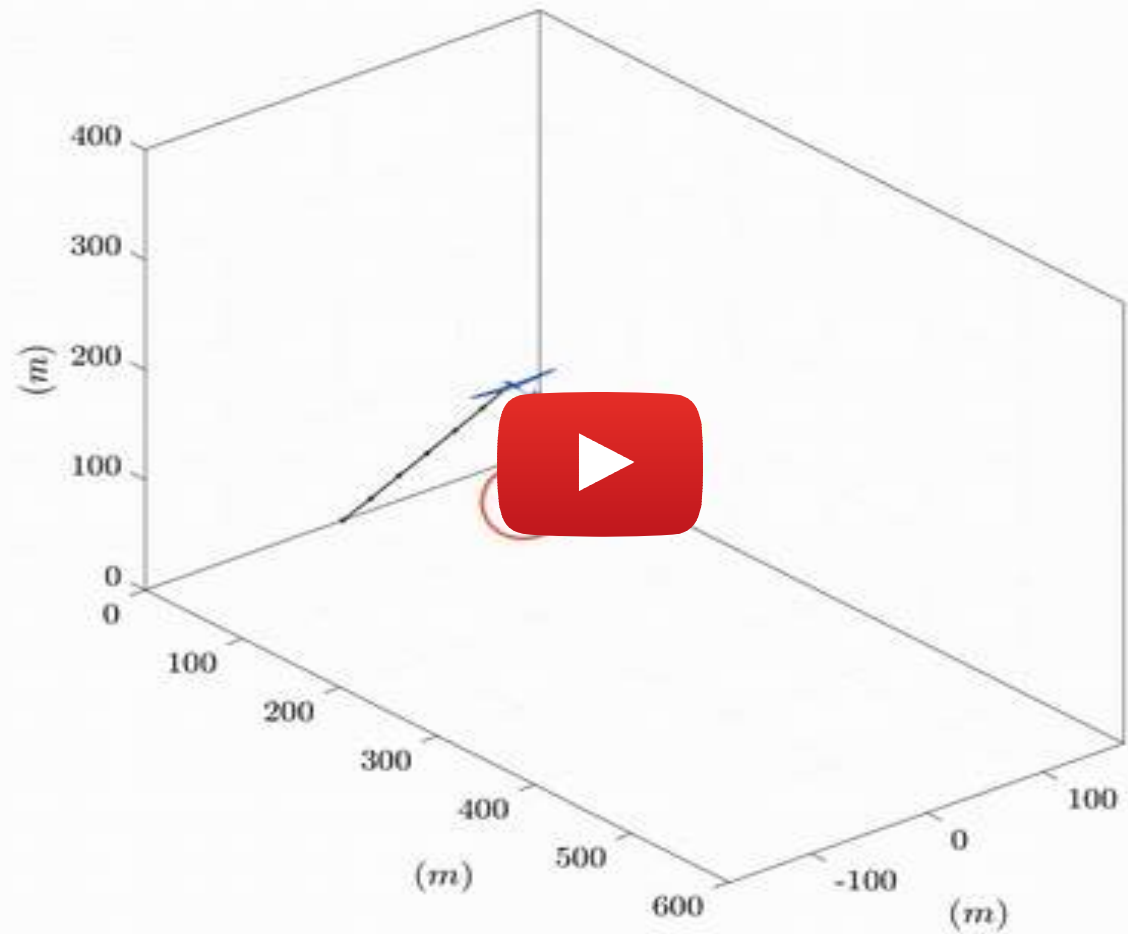



# Kite park layout

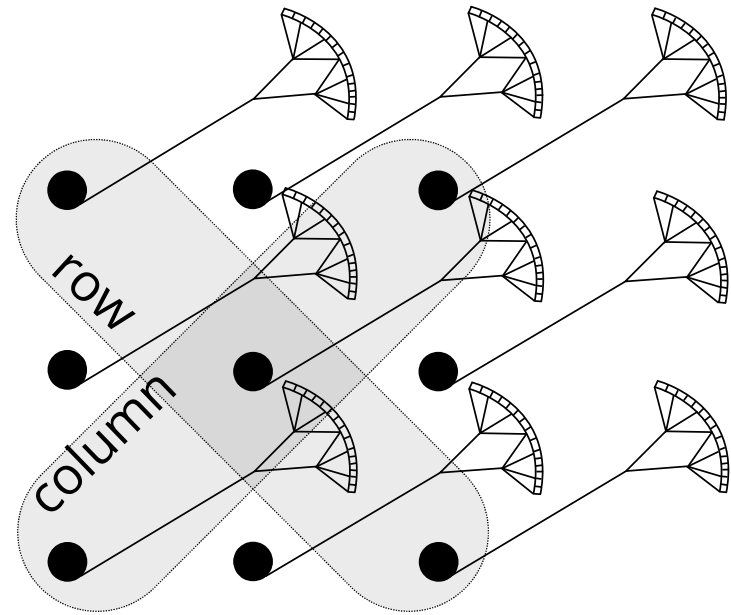
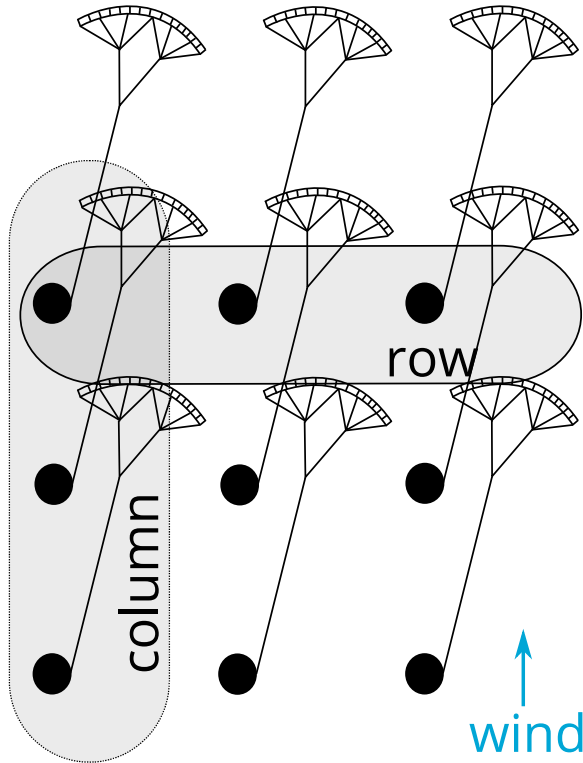

# Kite park power output

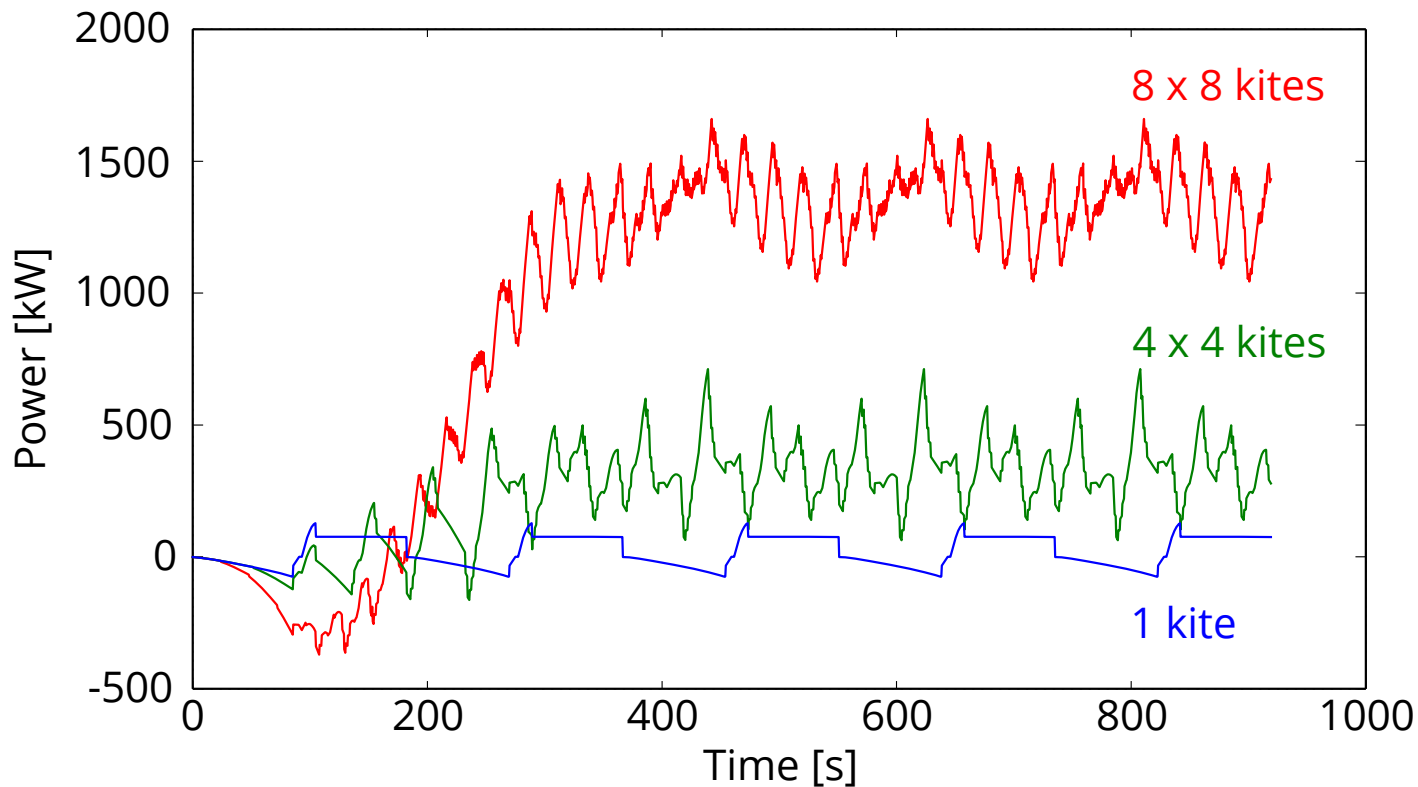

# Safety & reliability



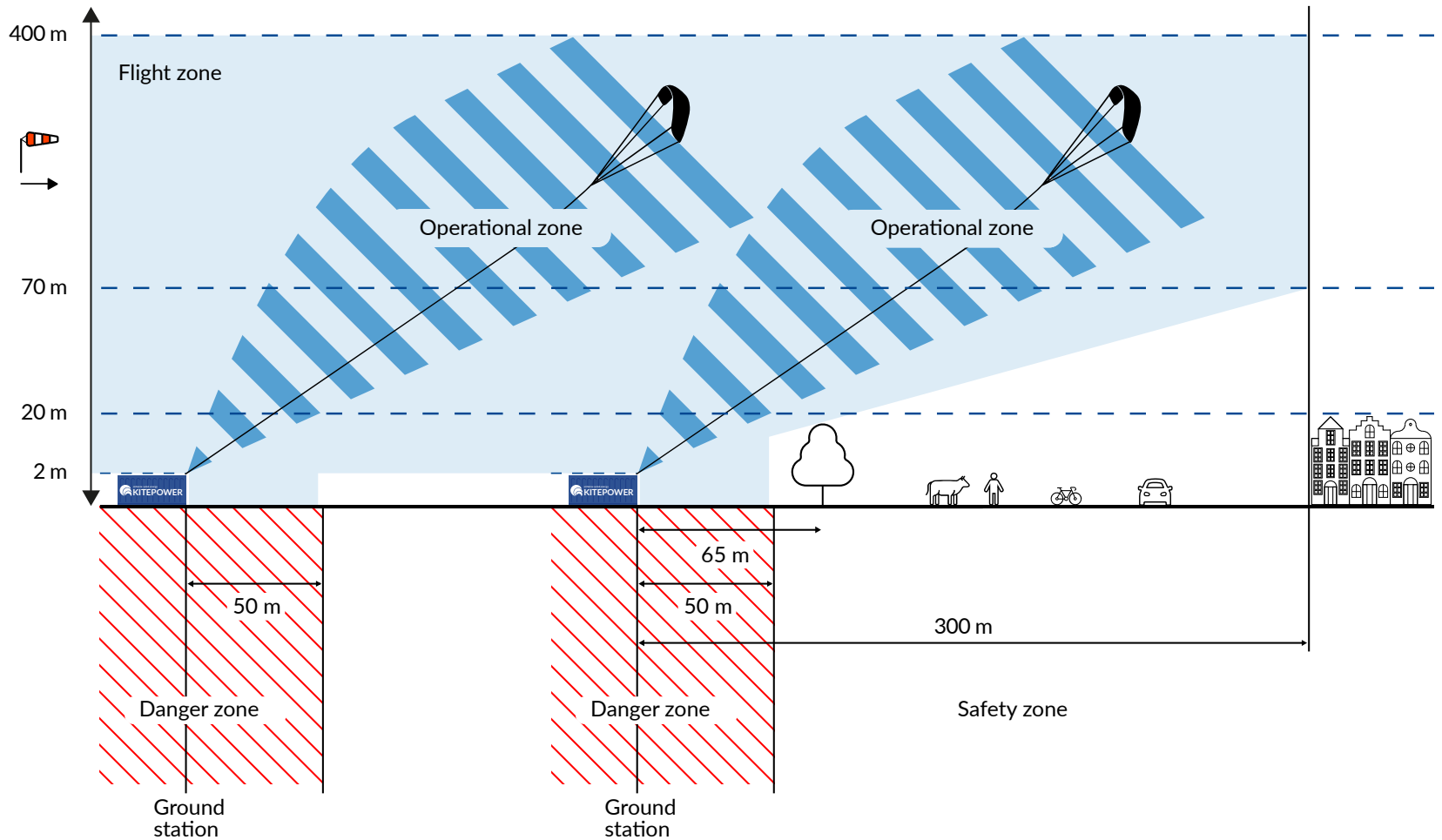

(C)



(A)



(B)



(D)



(E)





ETH Zürich

DTU

DTU

TU Delft

# Development as an industry

- Many bottom-up initiatives, e.g. by students and PhD researchers, only later picked up by academic staff
- Initially driven by research on control & optimization
- Full automation, reliability and materials are critical technical challenges
- Developed in parallel to conventional wind energy
- Since a few years also the wind energy community shows interest

# Infrastructure

- EU-H2020 doctoral school AWESCO (2015-2018)
- Industry association “Airborne Wind Europe”
- EAWC Technical Committee “Airborne Wind Energy”





- Marie Skłodowska-Curie Initial Training Network
- 4 work packages focussing on scientific challenges:
  - **Modelling and Simulation** (WP lead: TUD)
  - **System Design and Optimisation** (WP lead: ALU-FR)
  - **Sensors and Estimation** (WP lead: Xsens)
  - **Control Systems** (WP lead: TUM)

- 14 PhD projects, all contributing to relevant questions of industry
- 4 PhD projects supervised by TU Delft
- 10 EU-funded partners
- 2 CH-funded partners
- 3.4 M€ total budget

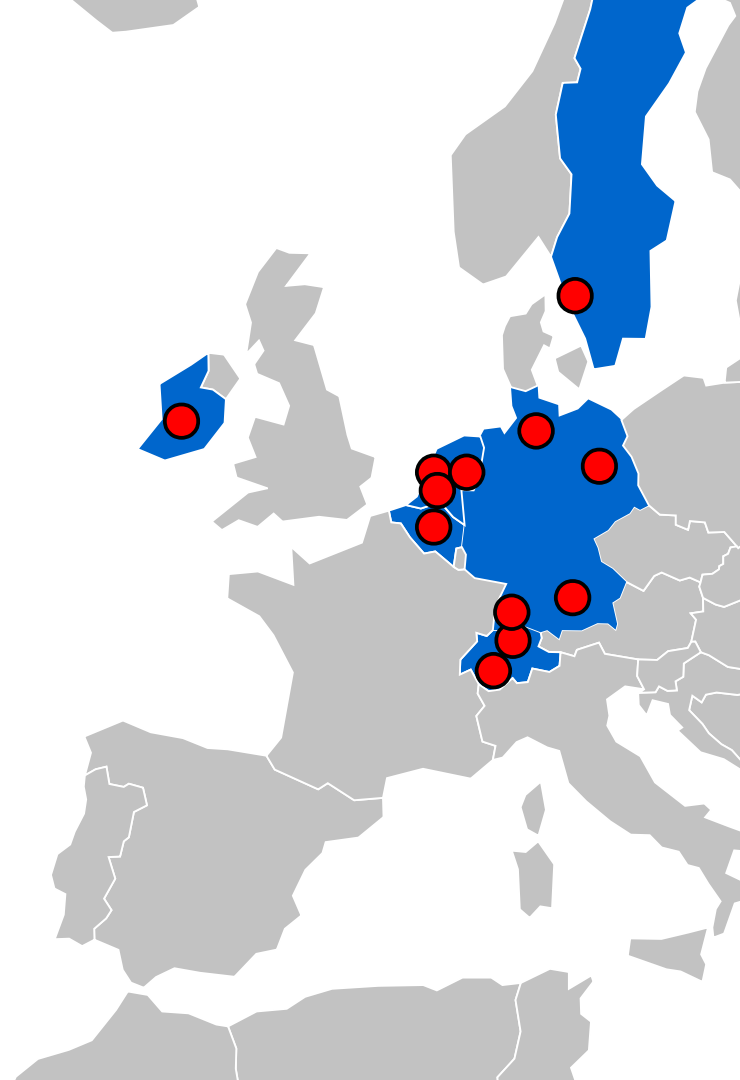



Photos: Per Rutquist



AWESCO members: (above) at the midterm project meeting (8 February, 2017), and (below) during a course (3–4 March, 2016)



# Impact of EU funding



## FP7

- **HAWE** - FP7-ENERGY
- **Highwind** - ERC

## Horizon 2020

- **AWESCO** - European Training Network
- **AMPYXAP3** - SME Instrument Phase I & II
- **REACH** - Fast Track to Innovation Pilot



# Impact of EU funding



## Horizon 2020

- **NEXTWIND** - SME Instrument Phase I & II
- **AWESOME** - SME Instrument Phase I & II
- **SKYPULL** - SME Instrument Phase I
- **TWINGTEC** - SME Instrument Phase I
- **TWINGPOWER** - Eurostars

# AWEC 2015 in Delft





**AWEC 2019, 15-16 October, Glasgow, United Kingdom**

Book of Abstracts, edited by Roland Schmehl, Oliver Tulloch, 164 pages.

ISBN 978-94-6366-213-0

doi:10.4233/uuid:57fd203c-e069-11e9-9fcb-441ea15f7c9c

shortdoi:10/dcjm

**AWEC 2017, 5-6 October, Freiburg, Germany**

Book of Abstracts, edited by Moritz Diehl, Rachel Leuthold, Roland Schmehl, 188 pages.

ISBN 978-94-6186-846-6

doi:10.4233/uuid:4c361ef1-d2d2-4d14-9868-16541f60edc7

shortdoi:10/cd54

**AWEC 2015, 15-16 June, Delft, The Netherlands**

Book of Abstracts, edited by Roland Schmehl, 123 pages.

ISBN 978-94-6186-486-4

doi:10.4233/uuid:6e92b8d7-9e88-4143-a281-08f94770c59f

shortdoi:10/bjhs

**AWEC 2013, 10-11 September, Berlin, Germany**

Book of Abstracts, edited by Guido Lütsch, Christian Hiemenz, Roald Koch, 77 pages.

ISBN 978-94-6186-848-0

doi:10.4233/uuid:f91af52c-4e76-4cf5-917a-129455b3fca9

shortdoi:10/c5j3

**AWEC 2011, 24-25 May, Leuven, Belgium**

Book of Abstracts, edited by Jacqueline De Bruyn, Moritz Diehl, Reinhart Paelinck, Richard Ruiterkamp, 73 pages.

ISBN 978-94-6018-370-6

doi:10.4233/uuid:54a23dff-74f9-4007-b1d6-e92e0c458491

shortdoi:10/czgh



# Questions?

- ✉ [r.schmehl@tudelft.nl](mailto:r.schmehl@tudelft.nl)
- 🐦 [twitter.com/kite\\_power](https://twitter.com/kite_power)
- 🏠 [awesco.eu](http://awesco.eu)

